

Engineering characteristics of dune sand-fine marble waste mixtures

Mohsin U. Qureshi^{*1}, Zafar Mahmood^{2a}, Qazi U. Farooq^{3b}, Qadir B.I.L. Qureshi^{4c},
Hajar Al-Handasi^{1d} and Ilhan Chang^{5e}

¹Faculty of Engineering, Sohar University, P.O. Box 44, P.C. 311, Sohar, Oman

²Department of Civil and Architectural Engineering, University of Buraimi, P.O. Box 890, P.C. 512, Buraimi, Oman

³Department of Civil Engineering, Islamic University of Madinah, Madinah, Saudi Arabia

⁴College of Engineering and Architecture, University of Nizwa, P.O. Box 33, P.C. 616, Nizwa, Oman

⁵Department of Civil Systems Engineering, Ajou University, Suwon 16499, Republic of Korea

(Received October 6, 2021, Revised January 21, 2022, Accepted January 24, 2022)

Abstract. Dune sands are poorly graded collapsible soils lacking fines. This experimental study explored the technical feasibility of sustainable invigoration of fine waste materials to improve the geotechnical properties of dune sand. The fine waste considered in this study is fine marble waste. The fine waste powder was mixed with dune sand at different contents (5, 10, 15, 20, 25, 50%), where the gradation, void ratio, compaction, and shear strength characteristics were assessed for each fine marble waste-dune sand blend. The geotechnical properties of the dune sand-fine marble waste mix delineated in this study reveal the enhancement in compaction and gradation characteristics of dune sand. According to the results, the binary mixture of dune sand with 20% of fine marble waste gives the highest maximum dry density and results in shear strength improvement. In addition, a numerical study is conducted for the practical application of the binary mix in the field and tested for an isolated shallow foundation. The elemental analysis of the fine marble waste confirms that the material is non-contaminated and can be employed for engineering applications. Furthermore, the numerical study elucidated that the shallow surface replacement of the site with the dune sand mixed with 20% fine marble waste gives optimal performance in terms of stress generation and settlement behavior of an isolated footing. For a sustainable mechanical performance of the fine marble waste mixed sand, an optimum dose of 20% fine marble waste is recommended, and some correlations are proposed. Thus, for improving dune sand's geotechnical characteristics, the addition of fine marble waste to the dune sand is an environment-friendly solution.

Keywords: dune sand; fine marble waste; numerical modelling; shallow foundation; shear strength

1. Introduction

The infrastructure development in the desert area of Oman requires sustainable ground improvement. The dune sands formed in the area are characterized as collapsible soils and are not suitable for supporting infrastructure due to their loose structure. The dune sands are usually fine-grained and poorly graded with a small amount of silt (Pease and Tchakerian 2002). As a general practice, engineers blend such sands with additives to enhance engineering performance. The success of the improvement method depends on many factors, such as properties of sand and the additive, purpose, field application method, environmental concerns and economy. Recently, the most successful method is the one that not only enhances the engineering properties of sand but also has a low carbon footprint (Chang *et al.* 2016, 2020). Using waste materials

as additives in sand improvement is more attractive to cut the carbon footprint associated with processing resources obtained from natural materials.

Studds and Miller (2010) and Shillaber *et al.* (2016) presented an approach to determine ground improvement works' embodied energy and carbon dioxide contribution. Therefore, it is interesting to utilize the fine marble waste as an additive to improve the bearing capacity of poorly graded dune sand. The production and disposal of fine particles while cutting marble is one of the marble industry's major problems. Around 50% of marble quarries are turned to waste during the cutting process (Bilgin *et al.* 2012). Several studies (Sivrikaya *et al.* 2014, Luodes *et al.* 2012) were devoted to stabilizing the problematic soils using waste produced by the stone industry. The marble wastes from the industry are currently destined to the landfill for expensive disposal. The marble quarries are located near the coastal city of Al Khaboura, Oman (Fig. 1), and the processing of marble takes place in the industrial zone of Sohar, Oman. The sustainable management of waste generated from quarrying operations and stone processing industries is an environmental concern. There is a potential of using fine marble waste to improve poorly graded dune sand.

Many studies (Al-Rawas *et al.* 2006, Mohamedzein and Al-Aghbari 2012) explore the alternative use of fines materials in Oman for various engineering applications.

*Corresponding author, Assistant Professor
E-mail: MQureshi@su.edu.om

^aAssistant Professor

^bAssistant Professor

^cAssistant Professor

^dB.Eng. Student

^eAssociate Professor

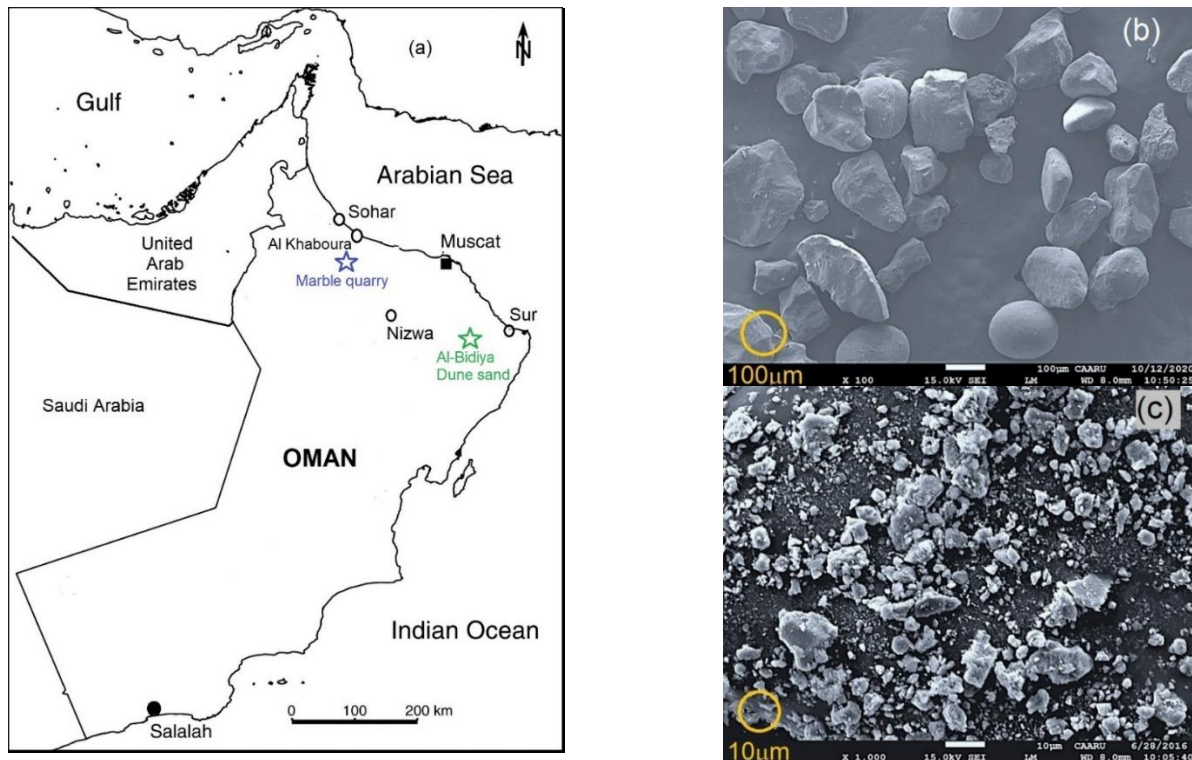

Fig. 1 (a) Location of sampling sites for fine marble waste and dune sand, Scanning electron microscope images of (b) dune sand and (c) fine marble waste

Deb *et al.* (2010) added plastic and non-plastic fines to the poorly graded sands in varying quantities to study the changes in compaction parameters. They concluded that adding fines up to a certain amount increases the maximum dry unit weight of poorly graded sands. The amount of increase depends on the uniformity coefficient value of the sand. In the past, various additives have been employed to improve the properties of soil; such as the use of cement and cement bypass dust (Al-Aghbari *et al.* 2009, Lopez-Querol *et al.* 2017), bentonite (O'Sadnick *et al.* 1995, Gueddouda *et al.* 2010, Saberian *et al.* 2018), ash (Mohamedzein and Al-Aghbari 2012), fine marble waste (Qureshi *et al.* 2018), biopolymer (Qureshi *et al.* 2014, 2015, 2017) biopolymer and fibres (Qureshi *et al.* 2019), shredded plastic waste (Kazmi 2020), reservoir sediments (Qureshi *et al.* 2021), lime and cement (Aziz *et al.* 2021), recycled concrete aggregates (Al-Kindi *et al.* 2016), and fibre reinforcement (Consoli *et al.* 2009). Likewise, Park *et al.* (2018) have reported that the addition of more than 20% fines to sand has a noticeable effect on the mix's quick undrained shear strength. Choo *et al.* (2017) improved the sand by adding kaolin clay and reported the critical and limiting fine content, porosity, and concept of interfine void ratio. They found that the critical fine content of binary mixture was 40%, and limiting fine content was around 80% to achieve optimum compression index and shear modulus of treated soil. Cubrinovski and Ishihara (2002) reported a decrease in void ratios (maximum and minimum) of sand by the addition of fines up to 30% (transition zone), which fill the inter-granular void spaces. Beyond the

transition zone, the void ratio is set to increase because sand particles are replaced with fines. Therefore, making a binary mixture of fine marble waste with poorly graded sand is expected to have improved engineering properties compared to pure sand.

However, apart from a study on utilizing reservoir sediment (Qureshi *et al.* 2021) and fine marble waste (Qureshi *et al.* 2018), no significant studies were conducted in Oman to utilise non-cementitious fine waste to improve the properties of dune sand for engineering purposes. In this regard, as an extension to the study by Qureshi *et al.* (2018), the present paper aims to propose an optimized mixture of sand-fine marble waste for a shallow surface replacement for the construction of small buildings on poorly graded dune sand. The authors aimed to elucidate the strength, compaction characteristics of desert sand mixed with fine marble waste powder at various proportions. In addition, numerical simulations to model isolated footing resting on pure and improved sand are reported using the COMSOL Multi-Physics program (COMSOL Inc. 2018). The later sections are detailing about the experimental results and the derived conclusions.

3. Experimental program

The experimental work of compaction ASTM D689 (ASTM 2012), direct shear ASTM D3080 (ASTM 2011), Atterberg's Limits ASTM D4318 (ASTM 2017) and gradation analysis ASTM D6913 (ASTM 2017) are by using the equipment manufactured by ELE International, U.K. The void ratios JGS 161 (JGS 2015) are determined

by manufacturing a machine shown in Fig. 2 at the Advanced Manufacturing Research Centre (AMRC) of the Intaj Suhar facility at Sohar University, Oman. To achieve the loosest possible state of geomaterials, the Japanese Geotechnical Society (JGS) Standard suggests filling the standard container by pouring material from a standard cone frustum at a very low speed (Cubrinovski and Ishihara 2002). The machine has a CNC-controlled linear mechanism that raises the cone frustum filled with geomaterials at controllable speed, thus eliminating human error. A scanning electron microscope equipped with energy-dispersive spectroscopy (EDS) unit (Model JSM 6360, Jeol, Tokyo, Japan) was used to investigate the material's phase composition and microstructural characteristics. Pure samples of the materials were used for SEM analysis.

3.1 Dune sand

Dune sand used in this study was sampled from Al-Bidiya in the northern part of Wahiba dunes (Fig. 1 (a)), in Al-Sharqia Region, which is about 200km to the south of Capital Muscat (22°24'51.9"N 58°49'57.7"E). The Wahiba Dune Sand, formed in the Quaternary period, comprises two physiographic units roughly divided into northern and southern regions. The Northern Wahiba is predominantly a large mega ridge system, whereas the Southern Wahiba mainly comprises linear dunes, sand sheets, and sabkha fields (Pease and Tchakerian 2002). Carbonate sands are present throughout the Wahiba Sand area, with some quartz-rich sands in the Southern region. The dune sand (S) used in this study is sampled from the Northern region. The micrograph of dune sand indicates sub-rounded particles and lack of fines as presented in Fig. 1(b).

The energy dispersive spectroscopy (EDS) analysis presented in Fig. 2 confirms calcium, carbon, and oxygen to be the dominant elements of the carbonate sand sampled from the northern ridge of Al Sharqia desert. The sand can be classified as poorly-graded sand (SP) according to the Unified Soil Classification System and ASTM D2487-17e1 (ASTM 2017). The sand has a specific gravity of 2.62 and a fine content of 3.5%. The standard proctor compaction test followed by ASTM D698-12e2 (ASTM 2012) derived a maximum dry unit weight of 16.54 kN/m³ and an optimum water content of 16.87%.

3.2 Fine marble waste

Marble is a metamorphic rock of limestone that consists predominantly of calcite and dolomite (Dietrich and Skinner 1979). In this study, calcite marble waste in a dust form was used. Fine marble waste was sampled from Al Khaboura Marble quarries located in North AlBatnah of Oman (Fig. 1(a)). Marble waste slurry is produced as a result of sawing and cutting of marble at the site. Water is then removed from the slurry at the factory, and fine marble waste is dumped at the landfill sites. Waste marble has a high fine content of 83%. The photomicrograph of fine marble waste (M) is presented in Fig. 1(c) indicates the potential of fine marble waste to fill in the voids between poorly graded sand particles, thereby improving its gradation.

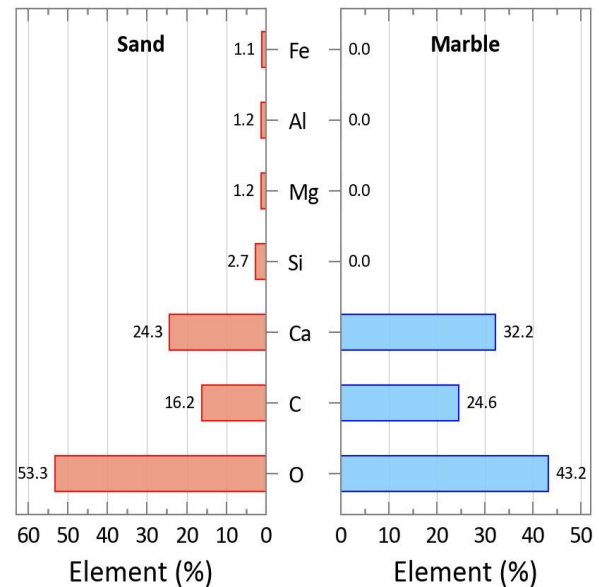

Fig. 2 Elemental analysis of the tested materials obtained from field emission scanning electron microscope with energy dispersive spectroscopy (EDS)

The inorganic fine marble waste (Fig. 2) shows a high proportion of calcium, carbon, and oxygen while has no metallic elements. Fine marble waste was dried in the oven at 110°C for 24 hours and passed through the No. 40 sieve (0.425 mm) before its usage in experimental work.

4. Experimental results and discussions

4.1 Index properties

Fine marble waste was added in percentages of 5, 10, 15, 20, 25 and 50% by dry weight of the sand. The required amount of fine marble waste was added to a dry sand sample passing the No. 4 sieve (4.75 mm). The sand and fine marble waste were mixed thoroughly to form a uniform sand-fine marble waste mixture. The gradation analysis and compaction test results on each mixture are summarized in Table 1. The grain size distribution for all mixtures and original sand and fine marble waste samples are plotted in Fig. 3. The gradation analysis indicates that the addition of fine marble waste improves the gradation of the sand-fine marble waste mix to a certain extent. To ensure reproducibility of the results, for each mixture, a large amount of the sample was prepared for different tests. Identical samples were tested, and the average value was obtained.

The variability of the measured quantities was assessed based on published guidelines. Average differences of less than 10 % were considered acceptable in this study. There is an overall increase in the maximum (e_{max}) and minimum (e_{min}) void ratios of sand by adding fine marble waste, as shown in Fig. 4. The test data evaluated regression relationships to assess e_{max} and e_{min} based on the fine marble waste contents (m).

Table 1 Index properties of dune sand and fine marble waste mixes

Material	Symbol	Sand (%)	Fine marble waste (%)	F_c (%)	G_s	C_u	C_c	USCS Classification
Sand	S	100	0	3.50	2.620	2.15	1.01	SP: Poorly graded sand
	SM05	95	5	7.79	2.618	1.99	1.00	SP-SM: Poorly graded sand with silt
	SM10	90	10	15.42	2.616	2.82	1.13	SM: Silty sand
	SM15	85	15	22.67	2.613	3.65	1.23	SM: Silty sand
	SM20	80	20	29.58	2.611	4.33	1.00	SC: Clayey sand
	SM25	75	25	32.34	2.609	5.18	1.17	SC: Clayey sand
	SM50	50	50	44.36	2.598	4.57	0.99	SC-SM: Silty clayey sand
Fine marble waste	M	0	100	83.00	2.575	9.47	0.77	CL: Lean clay

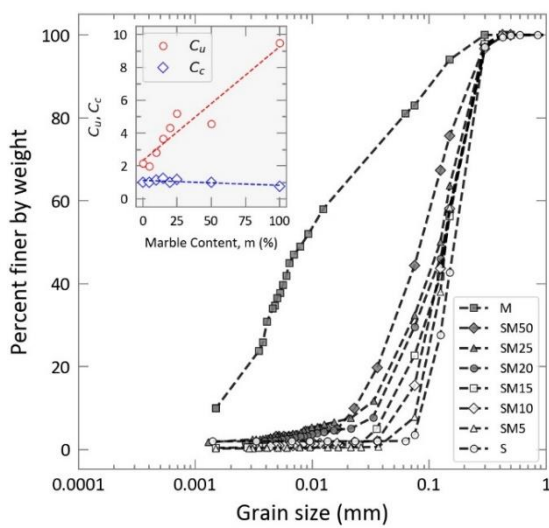

Fig. 3 Grain size distribution of the sand-fine marble waste mixes

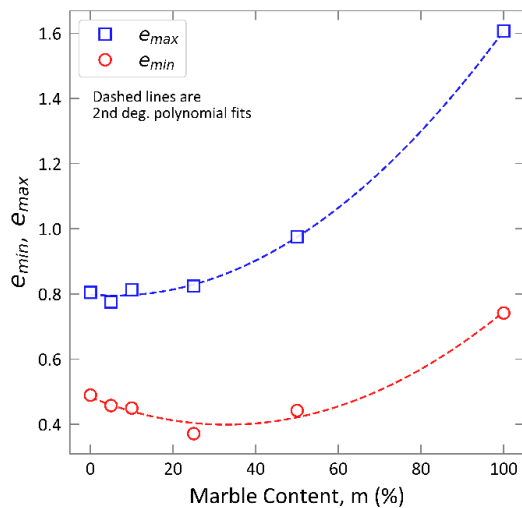

Fig. 4 Void ratios of sand-fine marble waste mixes

The observations made in this study validate the findings of Cubrinovski and Ishihara (2002) about the void ratio range ($\Delta e = e_{max} - e_{min}$) of sands treated with different

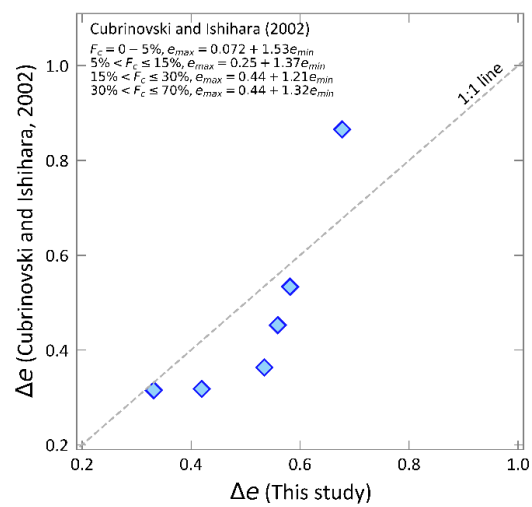

Fig. 5 Void ratio range of this study compared with the study reported by Cubrinovski and Ishihara (2002)

percentages of fines, as shown in Fig. 5. The data acquired from the gradation analysis are summarized in Table 1. The fine content increased from 3.5 percent for the virgin sand to 83% for the pure fine marble waste. There is also an increase in the uniformity coefficient (C_u) of sand by adding fine marble waste; the C_u increased from 2.15 (virgin sand, $F_c=3.5\%$) to 4.57 for sand mix having 44.36% fines and 50% fine marble waste.

According to Deb *et al.* (2010), the increment in the strength of a poorly graded sand by the optimised addition of fines is related to C_u . The maximum and minimum void ratios (JGS 2000) of sand are increased by adding fine marble waste with a minor drop at the lower percentages of fine marble waste (Fig. 4). The observation made in this study validates the conclusion made by Cubrinovski and Ishihara (2002) and Lade *et al.* (1998) about the increase in the void ratio of sand treated with higher percentages of fines, as shown in Fig. 5. Similarly, both maximum and minimum void ratios are increased by adding fine marble waste fines to the dune sand.

4.2 Compaction tests

Standard Proctor compaction tests were performed on

Table 2 Maximum dry unit weight and optimum moisture content (OMC) for each mixture

Compaction properties	Sand – fine marble waste mix							
	S	SM05	SM10	SM15	SM20	SM25	SM50	M
γ_{dmax} (kN/m ³)	16.54	16.70	16.69	16.97	17.79	17.71	17.15	13.60
OMC (%)	16.89	14.26	15.06	12.58	12.76	10.82	14.09	27.90

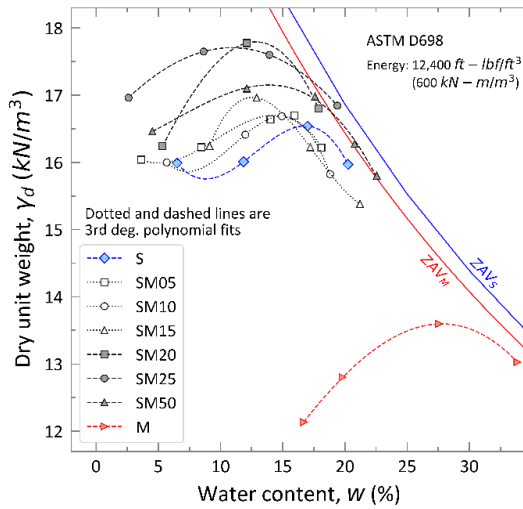

Fig. 6 Compaction test results on sand-fine marble waste mixes

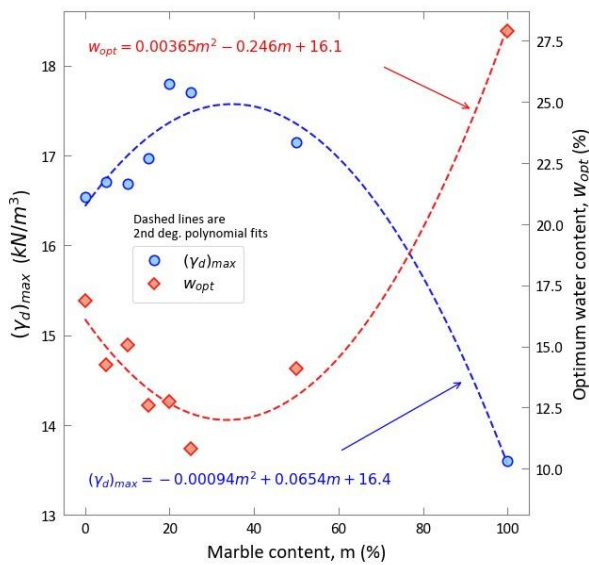

Fig. 7 Plot between the compaction parameters and the fine marble waste content

the mixtures following (ASTM D698-12e2 2012). The results of compaction tests for various mixtures are shown in Fig. 6. The data obtained for pure sand (S) is also shown in the figure for comparison purposes. The maximum dry unit weight is increased up to fine marble content of 20% and then decreased with the increase in fine marble waste content. Initially, the fine marble waste filled the voids between the sand particles, and once the voids are filled with fine marble waste (at about 15%), further increase in

the fine marble waste content decreases the maximum dry density, as shown in Fig. 8. The maximum dry unit weight and optimum content values for each mix are also presented in Table 2. The pure dune sand having imperfect roundness shows an optimum water content of 16.89% which is due to the lubrication requirement of particles for rearrangement. The thin film of water formed around particles facilitates the rearrangement which is a typical case in dune sands. With the addition of fine marble waste, the optimum water content of the mix reduces up to marble waste content of 25% and with further addition of marble waste to the dune sand an increase in optimum water content is observed as shown in Fig. 7.

4.3 Direct shear strength

Direct shear strength tests were performed on the sand, fine marble waste and SM05, 10, 15, 20, 25 and 50 specimens. The specimens (60 mm in width × 60 mm in length × 30 mm in height) prepared for conducting the direct shear tests were prepared by compacting the mixes at their respective optimum moisture content to achieve maximum dry densities. Thereafter preparation, the specimens were dried in an oven at 110°C for 72 hours to be at the exact condition of moisture content at the time of direct shear tests. The tests were performed at different levels of normal stresses (σ_n) to compute shear strength parameters, i.e., cohesion, c and angle of internal friction, ϕ at peak, using the Mohr-Coulomb failure criteria. All the tests were performed at a constant horizontal displacement rate of 0.5mm/min. The tests were performed at three normal stress levels, i.e., 50.8, 110.9, and 160.7 kPa for each mix type. To ensure reproducibility of the results, a large amount of the mixture was prepared for each fine marble waste content for each test. At least two identical tests were conducted for a single condition to obtain reliable values. The test results displaying the plot between shear stress and shear displacement for each mix are shown in Fig. 8.

The shear strength parameters calculated by using the Mohr-Coulomb failure criteria are also shown in Fig. 8 for each mix type. Fig. 9 shows the plot between shear strength and the fine marble waste content at three normal stress levels. The mix having a fine marble waste percentage of 15-20% shows optimal performance. The change in cohesion and angle of internal friction of sand fine marble waste mix specimens is plotted against the fine marble waste content in Fig. 10.

It can be seen that the angle of internal friction first increases and then decreases; however, the cohesion increases with the increase in the percentage of fine marble

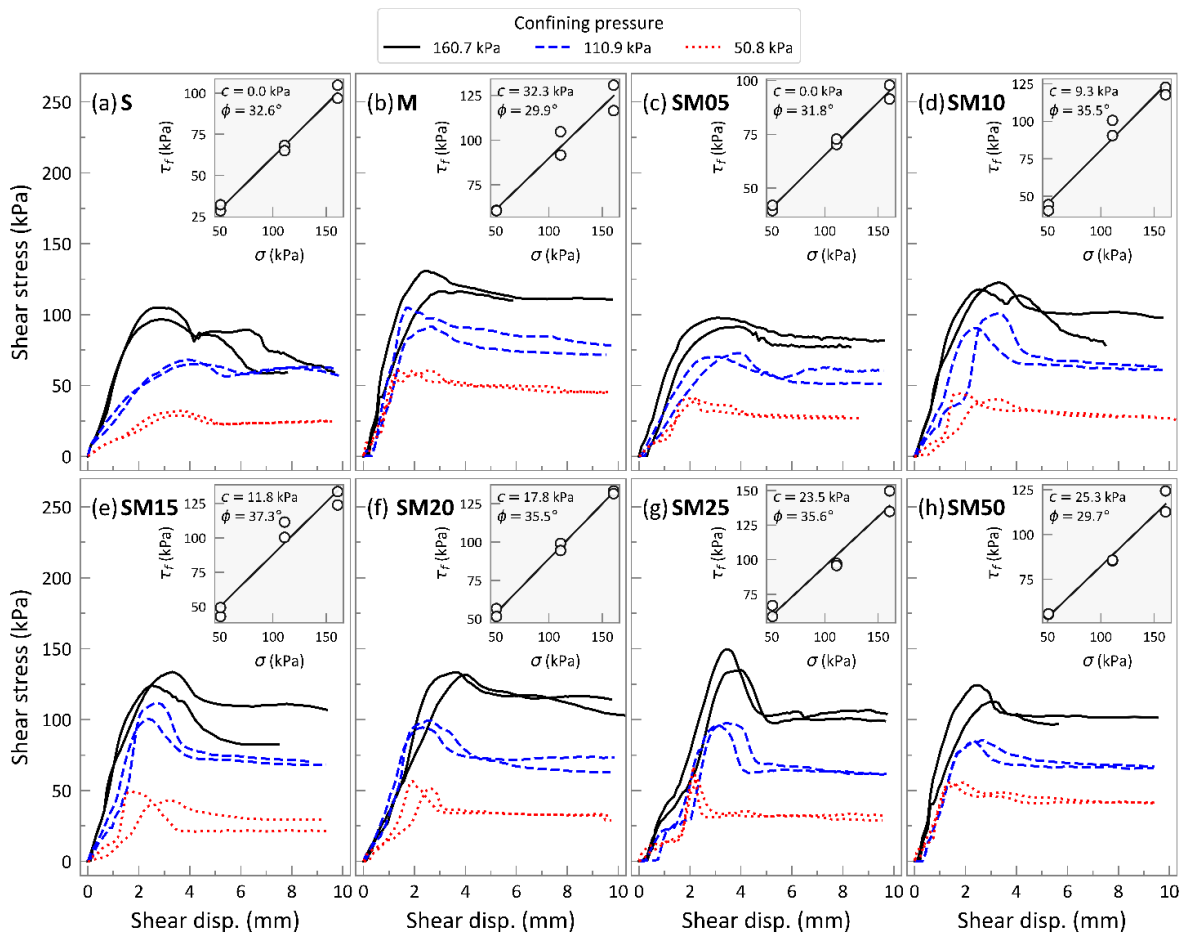

Fig. 8 Direct shear strength results on dune sand – fine marble waste mixes

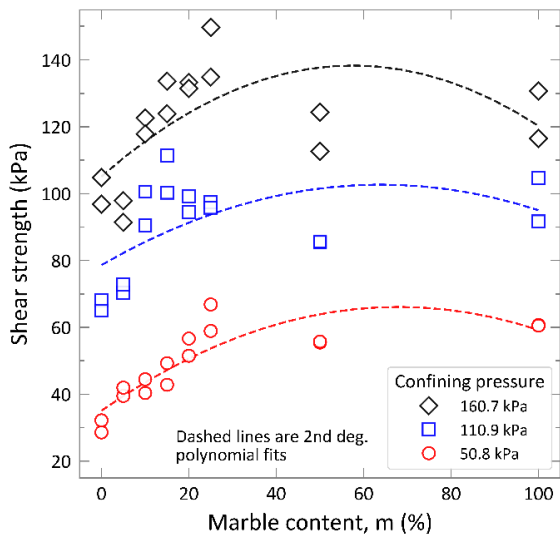

Fig. 9 Change in shear strength with the addition of fine marble waste in the sand at different confining levels

waste in the sand. The cohesion is around 32kPa for pure fine marble waste and 17.8 kPa for sand with 20% fine marble waste content, which is considered a substantial improvement in the shear strength of cohesionless dune

sand. Since the study aims to propose a fine marble waste – sand mix for the replacement of shallow loose sand. So, as per the general observation of Figs. 7 and 9, SM20 provides optimum density and shear strength for the case of shallow surface replacement; therefore, it is recommended to study the field application of SM20 by using numerical modelling.

4.4 Numerical modelling

An increase in inter-particle cohesion of the fine marble waste mixed sand is expected to provide significant ground improvement in practical geotechnical applications. The performance of improved soil was evaluated by using FEM based foundation analysis. The FEM analysis has been conducted by utilizing the geomechanics module of the COMSOL Multiphysics program (COMSOL Inc. 2018). The module effectively evaluated various foundation engineering problems (Farooq and Naqash 2021, Harireche *et al.* 2021). The foundation model was articulated by applying a circular loading of unit radius on the surface. In addition, the axisymmetric (cylindrical) soil strata have been considered with natural soil underlying the treated soil layer. The complete geometrical arrangement, dimensions of footing and soil layers are shown in Fig. 11.

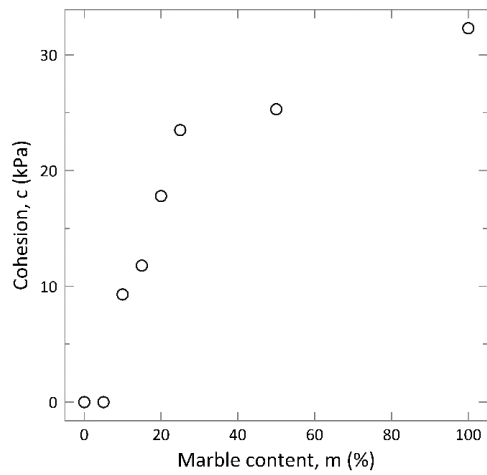

(a) Cohesion

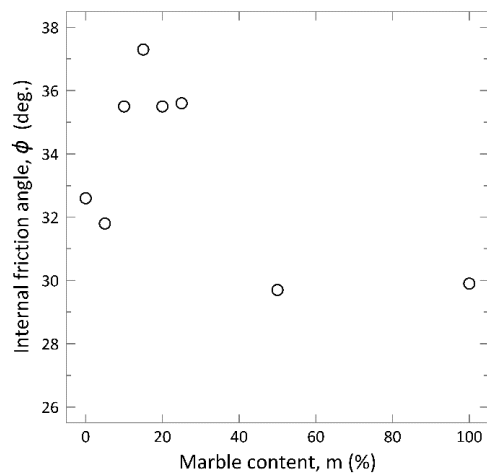

(b) Angle of internal friction

Fig. 10 Change in the shear strength parameters with the addition of fine marble waste in sand

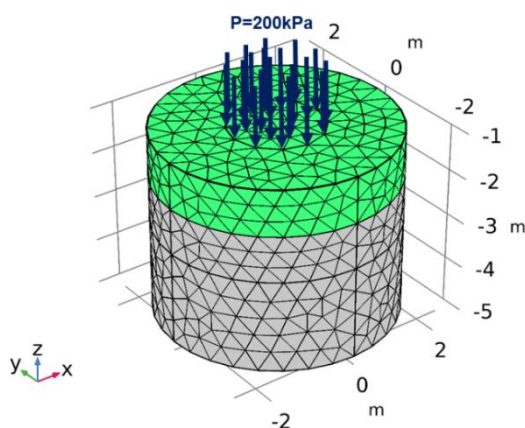

Fig. 11 Typical geometry of the model with 1m replacement

The foundation is subjected to a building load of 200 kPa. The optimized fine marble waste treated ratio "SM20" has been used in the numerical study. The foundation is modelled on three ground conditions, 1) dune sand, 2) 1 m

Table 3 Input parameters for FEM analysis based on experimental data

Material Property	Sand	SM20
Unit Weight γ (kN/m ³)	16.541	17.793
Friction Angle ϕ (degrees)	31.7	35.5
Cohesion c (kPa)	0	17.8
Elastic modulus* E (MPa)	25	50
Poisson's ratio* ν	0.3	0.3

surface replacement with SM20, and 3) 2 m surface replacement with SM20. The Mohr-coulomb elastoplastic material model is applied to simulate the soil behavior under dry conditions. The bottom of the analyzed soil matrix is considered a spring foundation with elastic properties, identical to that of the natural sand. At the same time, the curved surface along the z-axis is assumed as roller support.

The elastic modulus and Poisson's ratio values are adopted per the Canadian Geotechnical Society's foundation engineering manual guideline. The values are primarily based on friction angle, cohesion, and the density of the soils (CGS, 2006).

The settlement analysis results for the foundation model are expressed in Fig. 12. The fine marble waste treatment has remarkably reduced the overall foundation settlement. The 1 m soil replacement with SM20 decrease the foundation settlement up to 26% (Fig. 12(b)). Whilst, 2 m soil replacement yields about 33% reduction in foundation settlement (Fig. 12(c)).

The volumetric strain evaluation results are in good compromise with the overall settlement data. The fine marble waste content has reduced the volumetric contraction on foundation edges, as indicated in Fig. 13. The diminutive bulging on the soil surface has also been reduced. As far as volumetric strain is concerned, both 1m and 2m treatment has revealed almost the same results. This can be observed by comparing Fig. 13(b) and c. The stress distribution in the soil foundation system is indicated by the pressure diagram (Fig. 14) The pressure at any point on the figures represents the 1st invariant of the stress tensor.

Since the concrete foundation carries most of the stress, the minimum and maximum stresses lie within the same range and location, i.e., in the concrete zone. However, a more yellow portion can be seen in Fig. 14(a); this reflects slightly higher soil stresses in the dune sand case than the 1-m and 2-m soil treatment cases. The overall settlement for all three cases, along the model geometry's centerline, is summed up in Fig. 15(a), whilst the vertical stress profile is shown in Fig. 15(b).

The soil treatment has effectively reduced the overall settlement in the concrete foundation and the soil. As a result, the rigid concrete foundation has uniform settlement along with its 50 cm depth.

The 2m soil replacement case has better performance against settlement as compared to the 1-m case. The soil

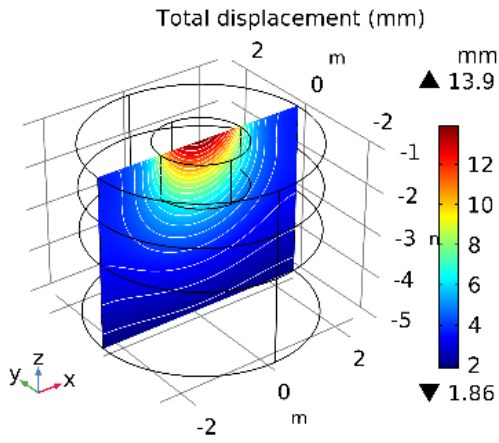

(a) Pure sand

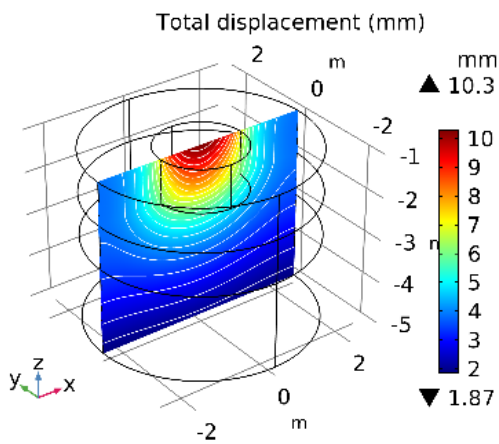

(b) 1m replacement with SM20

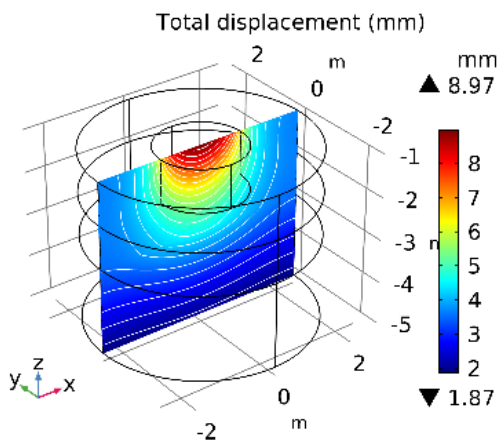

(c) 2m replacement with SM20

Fig. 12 Comparison of total deformation

treatment is proved to be effective for settlement control throughout the influence zone. The vertical stress for all cases decreases sharply with respect to the depth in the concrete zone (Fig. 15b). There is an abrupt change at the middle of the foundation cross-section due to the absence of flexural stresses. The induced vertical stress on the natural ground is reduced with the soil treatment. There is a marginal difference of vertical stress value at 3m depth for 1 and 2m soil substitution, with the former showing a slightly higher value.

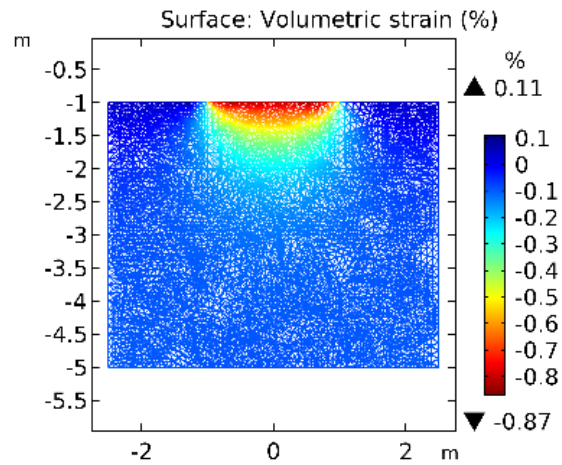

(a) Pure sand

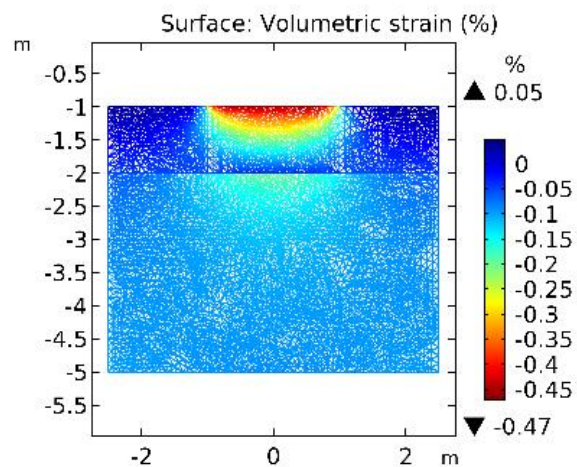

(b) 1m replacement with SM20

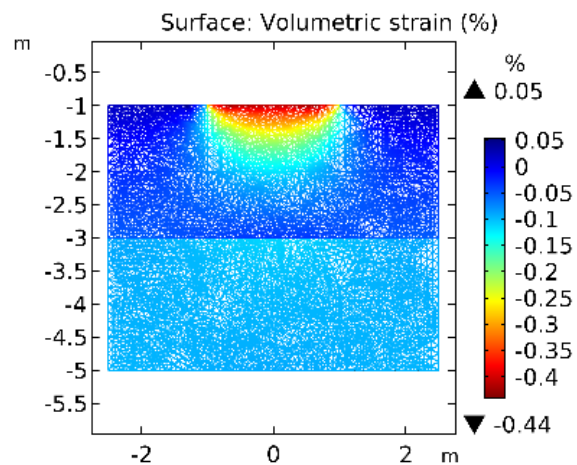

(c) 2m replacement with SM20

Fig. 13 Comparison of volumetric strain in Z-X plane

5. Conclusions

The present study was conducted to investigate the possibility of improving dune sands' engineering properties by adding fine marble waste. In addition, management of fine marble waste and efficient resource utilization by reusing the waste has been addressed, which are the domains of novel low carbon technologies and sustainable

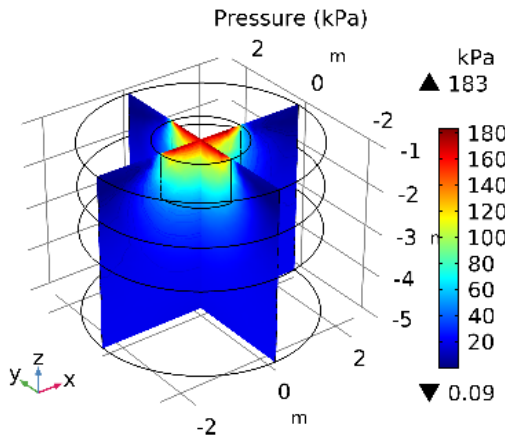

(a) Pure sand

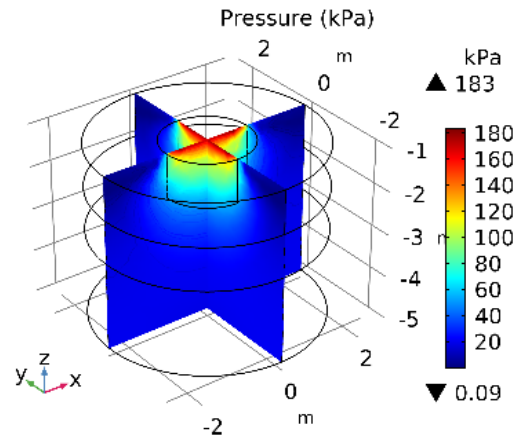

(a) Pure sand

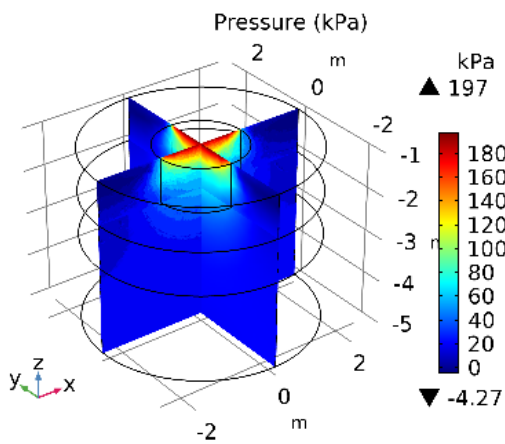

(b) 1m replacement with SM20

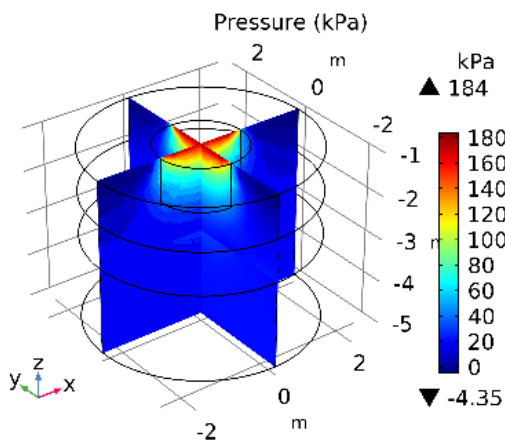

(c) 2m replacement with SM20

Fig. 14 Comparison of stresses

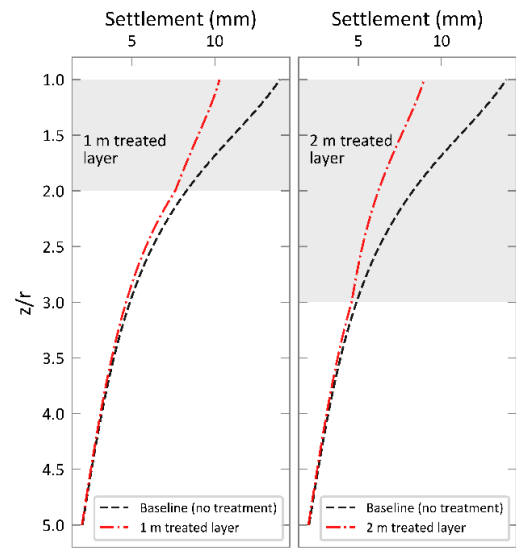

(a) Settlement

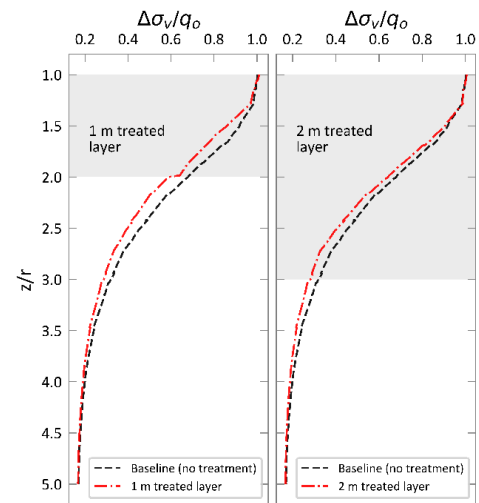

(b) Normalized vertical stress

Fig. 15 Comparison of stresses and settlement

development. Samples of dune sand (classified as SP) and fine marble waste (classified as CL) collected from the Al-Sharqia desert and the marble quarry of Al Khaboura, Oman, respectively, were mixed to study their engineering properties. The fine marble waste was added in percentages by weight of dry sand ranging from 5 to 50 % to make the binary mixtures. The binary mixtures, pure sand and fine marble waste were performed tests such as void ratio, gradation analysis, compaction, elemental analysis, scanning electron microscope analysis, and direct shear.

Additional research should investigate the effects on the strength compressibility of dune sand's binary mixture with fine marble waste. Based on the results presented in this paper, the following conclusions can be drawn:

- The binary mixtures give a much higher maximum dry unit weight than the dune sand. The addition of fine marble waste in the sand has improved the maximum dry unit up to a treatment ratio of 20%; however, the optimum water content (OMC) increases from 16.8% for pure sand to 27.9% for pure fine marble waste.
- The direct shear tests showed that the sand-fine marble waste mixtures possess both cohesion (c) and angle of internal friction (ϕ), indicating that the fine marble waste acted as a cementing agent between the sand particles. The fine marble waste substantially increases the shear strength of the treated sand. The shear strength increases with fine marble waste content up to 20%, and then after that, it decreases with the increase in sediment content.
- The elemental analysis of the fine marble waste confirmed the material as non-contaminated and suitable for engineering application without any environmental issues. On the other hand, the fine marble waste has no monetary value since it is a waste. If employed in ground improvement, it eliminates the need for its disposal in landfills. Therefore, the mixing of fine marble waste powder to sand can improve the properties of desert sand for shallow foundations.
- The results show that the addition of fine marble waste can improve dune sand's engineering properties. The laboratory test results indicated significant increases in the maximum dry unit weight and enhancement in gradation. The addition of fine marble waste to sand has improved the uniformity coefficient of the sand to some extent, and both the maximum and minimum void ratios are increased as well.
- The experimental results for soil improvement are evaluated for practical applications by FEM analysis performed for an isolated footing. The sand treated with fine marble waste has shown a reduced foundation settlement overall and improved stress transformation.

Acknowledgements

The research described in this paper was supported by the financial support provided by Sohar University, Oman. The authors are also indebted to their colleagues at the Sohar University for continuous support during the laboratory experimental programs.

References

- Al-Aghbari, M.Y., Mohamedzein, Y.E.A. and Taha, R. (2009), "Stabilisation of desert sands using cement and cement dust", *Proceedings of the Institution of Civil Engineers - Ground Improvement*, **162**(3), 145-151. <https://doi.org/10.1680/grim.2009.162.3.145>
- Al-Kindi, N., Al-Moqbali, A., Qureshi, M., Al-Shidi, A. and Al-Aldhen, I. (2016), "Mechanical characteristics of recycled concrete aggregates as backfill material", *Int. J. Appl. Eng. Res.*, **11**(2), 1342-1346.
- Al-Rawas, A.A., Mohamedzein, Y.E.A., Al-Shabibi, A.S., and Al-Katheiri, S. (2006), "Sand-attapulgitic clay mixtures as a landfill liner", *Geotech. Geol. Eng.*, **24**(5), 1365-1383. <https://doi.org/10.1007/s10706-005-2214-7>
- ASTM D2487-17e1. (2017), Standard Practice for Classification of Soils for Engineering Purposes (Unified Soil Classification System). *ASTM International, West Conshohocken, PA*. www.astm.org.
- ASTM D3080/D3080M-11. (2011), Standard Test Method for Direct Shear Test of Soils Under Consolidated Drained Conditions. *ASTM International, West Conshohocken, PA*. [Www.Astm.Org](http://www.Astm.Org). <https://www.astm.org/Standards/D3080>.
- ASTM D4318-17e1. (2017), Standard Test Methods for Liquid Limit, Plastic Limit, and Plasticity Index of Soils. *ASTM International, West Conshohocken, PA*. www.astm.org.
- ASTM D6913 / D6913M - 17. (2017), Standard Test Methods for Particle-Size Distribution (Gradation) of Soils Using Sieve Analysis. *ASTM International, West Conshohocken, PA*. [Www.Astm.Org](http://www.Astm.Org). <https://www.astm.org/Standards/D6913>.
- ASTM D698-12e2. (2012), Standard Test Methods for Laboratory Compaction Characteristics of Soil Using Standard Effort (12 400 ft-lbf/ft³ (600 kN-m/m³)). *ASTM International, West Conshohocken, PA*. www.astm.org.
- Aziz, M., Sheikh, F.N., Qureshi, M.U., Rasool, A.M. and Irfan, M. (2021), "Experimental study on endurance performance of lime and cement-treated cohesive soil", *KSCE J. Civil Eng.*, <https://doi.org/10.1007/s12205-021-2154-7>.
- Bilgin, N., Yeprem, H. A., Arslan, S., Bilgin, A., Günay, E. and Maroglu, M. (2012), "Use of waste marble powder in brick industry", *Constr. Build. Mater.*, **29**, 449-457. <https://doi.org/10.1016/j.conbuildmat.2011.10.011>.
- CGS. (2006). *Canadian Foundation Engineering Manual* (4th Ed.). Canadian Geotechnical Society.
- Chang, I., Im, J. and Cho, G.C. (2016), "Introduction of microbial biopolymers in soil treatment for future environmentally-friendly and sustainable geotechnical engineering", In *Sustainability (Switzerland)*, <https://doi.org/10.3390/su8030251>.
- Chang, I., Lee, M., Tran, A.T.P., Lee, S., Kwon, Y.M., Im, J. and Cho, G.C. (2020), "Review on biopolymer-based soil treatment (BPST) technology in geotechnical engineering practices", *Transportation Geotechnics*, <https://doi.org/10.1016/j.trgeo.2020.100385>.
- Choo, H., Lee, W. and Lee, C. (2017), "Compressibility and small strain stiffness of kaolin clay mixed with varying amounts of sand", *KSCE J. Civil Eng.*, **21**(6), 2152-2161. <https://doi.org/10.1007/s12205-016-1787-4>.
- COMSOL Inc. (2018), COMSOL Multiphysics Reference Manual (version 5.3a). *Comsol*.
- Consoli, N.C., Vendruscolo, M.A., Fonini, A. and Rosa, F.D. (2009), "Fiber reinforcement effects on sand considering a wide cementation range", *Geotext. Geomembranes*, **27**(3), 196-203. <https://doi.org/10.1016/j.geotexmem.2008.11.005>.
- Cubrinovski, M. and Ishihara, K. (2002), "Maximum and minimum void ratio characteristics of sands", *Soils Found.*, **42**(6), 65-78. https://doi.org/10.3208/sandf.42.6_65.
- Deb, K., Sawant, V.A. and Kiran, A.S. (2010), "Effects of fines on compaction characteristics of poorly graded sands", *Int. J. Geotech. Eng.*, **4**(2), 299-304. <https://doi.org/10.3328/IJGE.2010.04.02.299-304>.
- Dietrich, R.V. and Skinner, B.J. (1979), "Rocks and rock minerals", *John Wiley and Sons, New York*, Wiley. <https://doi.org/10.1002/gj.3350150110>.
- Farooq, Q.U. and Naqash, M.T. (2021), "Performance of shallow building foundations under infrequent rainfall patterns at Al-Madinah, Saudi Arabia", *The Open Civil Eng. J.*, **15**(1), 91-103. <https://doi.org/10.2174/1874149502115010091>.
- Gueddouda, M.K., Lamara, M., Abou-bekr, N. and Taibi, S. (2010), "Hydraulic behaviour of dune sand-bentonite mixtures under confining stress", *Geomech. Eng.*, **2**(3). <https://doi.org/10.12989/gae.2010.2.3.213>.

- Harireche, O., Naqash, M.T. and Farooq, Q.U. (2021), "A full numerical model for the installation analysis of suction caissons in sand", *Ocean Eng.*, **234**, 109173. <https://doi.org/10.1016/j.oceaneng.2021.109173>.
- JGS 161. (2015), Test method for minimum and maximum densities of sands (JIS A1224). *Japanese Geotechnical Society Standards: Laboratory Testing Standards of Geomaterial, 1*.
- Kazmi, Z.A. (2020), "Improvement in shear strength characteristics of desert sand using shredded plastic waste", *Geomech. Eng.*, **20**(6), 497-503. <https://doi.org/10.12989/gae.2020.20.6.497>.
- Lade, P.V., Liggio, C.D. and Yamamuro, J.A. (1998), "Effects of non-plastic fines on minimum and maximum void ratios of sand", *Geotech. Test. J.*, **21**(4), 336-347. <https://doi.org/10.1520/gtj11373j>.
- Lopez-Querol, S., Arias-Trujillo, J., GM-Elipse, M., Matias-Sanchez, A. and Cantero, B. (2017), "Improvement of the bearing capacity of confined and unconfined cement-stabilized aeolian sand", *Constr. Build. Mater.*, **153**. <https://doi.org/10.1016/j.conbuildmat.2017.07.124>.
- Luodes, H., Kauppila, P.M., Luodes, N., Aatos, S., Kallioinen, J., Luukkanen, S. and Aalto, J. (2012), "Characteristics and the environmental acceptability of the natural stone quarrying waste rocks", *Bull. Eng. Geol. Environ.*, **71**(2), 257-261. <https://doi.org/10.1007/s10064-011-0398-z>.
- Mohamedzein, Y.E.A. and Al-Aghbari, M.Y. (2012), "The use of municipal solid waste incinerator ash to stabilize dune sands", *Geotech. Geol. Eng.*, **30**(6), 1335-1344. <https://doi.org/10.1007/s10706-012-9548-8>.
- O'Sadnick, D.L., Simpson, B.E. and Kasel, G.K. (1995), Evaluation and performance of a sand/bentonite liner. *Geoenvironment 2000@ SCharacterization, Containment, Remediation, and Performance in Environmental Geotechnics*, 688-701.
- Park, T.W., Kim, H.J., Tanvir, M.T., Lee, J.B. and Moon, S.G. (2018), "Influence of coarse particles on the physical properties and quick undrained shear strength of fine-grained soils", *Geomech. Eng.*, **14**(1), 99-105. <https://doi.org/10.12989/gae.2018.14.1.099>.
- Pease, P.P. and Tchakerian, V.P. (2002), "Composition and sources of sand in the Wahiba Sand Sea, Sultanate of Oman", *Annals of the Association of American Geographers*, **92**(3), 416-434. <https://doi.org/10.1111/1467-8306.00297>.
- Qureshi, M.U., Bessaih, N., Al-Sadrani, K., Al-Falahi, S. and Al-Mandhari, A. (2014), *Shear strength of Omani sand treated with biopolymer*, (Eds., Bouazza, Abdulmalek, Yuen, Samuel T.S., Brown, Bruce), *Proceedings of the 7th International Congress on Environmental Geotechnics: Iceg2014*. [Barton, ACT]: Australia. <https://search.informit.org/doi/abs/10.3316/informit.000991677892416>.
- Qureshi, M.U., Al-Hilly, A., Al-Zeidi, O., Al-Barrami, A. and Al-Jabri, A. (2019), "Vane shear strength of bio-improved sand reinforced with natural fibre", *Proceedings of the E3S Web of Conferences*, 92. <https://doi.org/10.1051/e3sconf/20199212004>.
- Qureshi, Mohsin U., Al-Sawafi, B., Al-Washahi, M., Al-Saidi, M., and Al-Badi, S. (2018), *The Sustainable Use of Fine Marble Waste Powder for the Stabilization of Desert Sand in Oman* (pp. 303-313). Springer, Cham. https://doi.org/10.1007/978-3-319-61612-4_25.
- Qureshi, Mohsin U., Chang, I. and Al-Sadarani, K. (2017), "Strength and durability characteristics of biopolymer-treated desert sand", *Geomech. Eng.*, **12**(5), 785-801. <https://doi.org/10.12989/gae.2017.12.5.785>.
- Qureshi, Mohsin Usman, Al-Qayoudhi, S., Al-Kindi, S., Al-Hamdani, A. and Al-Sadrani, K. (2015), "The effects of slaking on the durability of bio-improved sand", *Int. J. Sci. Eng. Res.*, **6**(11). <http://www.ijser.org>.
- Qureshi, M.U., Alsaïdi, M., Aziz, M., Chang, I., Rasool, A.M. and Kazmi, Z.A. (2021), "Use of reservoir sediments to improve engineering properties of dune sand in Oman", *Appl. Sci.*, **2021**(4), 1620. <https://doi.org/10.3390/app11041620>.
- Saberian, M., Moradi, M., Vali, R. and Li, J. (2018), "Stabilized marine and desert sands with deep mixing of cement and sodium bentonite", *Geomech. Eng.*, **14**(6), 553-562. <https://doi.org/10.12989/gae.2018.14.6.553>.
- Shillaber, C.M., Mitchell, J.K. and Dove, J.E. (2016), "Energy and carbon assessment of ground improvement works. II: working model and example", *J. Geotech. Geoenviron. Eng.*, **142**(3), 04015084. [https://doi.org/10.1061/\(asce\)gt.1943-5606.0001411](https://doi.org/10.1061/(asce)gt.1943-5606.0001411).
- Sivrikaya, O., Kiyildi, K.R. and Karaca, Z. (2014), "Recycling waste from natural stone processing plants to stabilise clayey soil", *Environ. Earth Sci.*, **71**(10), 4397-4407. <https://doi.org/10.1007/s12665-013-2833-x>.
- Studds, P. and Miller, Z.M. (2010), "Sustainable material reuse solutions for dredged sediments", *Int. J. Sustain. Eng.*, **3**(1), 33-39. <https://doi.org/10.1080/19397030903380960>.

IC