

An adaptive neuro-fuzzy approach using IoT data in predicting springback in ultra-thin stainless steel sheets with consideration of grain size

Jing Zhao¹, Lichun Wan^{*2}, Mostafa Habibi^{3,4,5,6} and Ameni Brahmia⁷

¹School of Computer, Wuhan Donghu University, Wuhan 430212, Hubei, China

²College of Management, Wuhan Donghu University, Wuhan 430212, Hubei, China

³Department of Biomaterials, Saveetha Dental College and Hospital, Saveetha Institute of Medical and Technical Sciences, Chennai 600 077, India

⁴Universidad UTE, Facultad de Arquitectura y Urbanismo, Calle Rumipamba S/N y Bourgeois, Quito 170147, Ecuador

⁵Department of Mechanical Engineering, Faculty of Engineering, Haliç University, 34060, Istanbul, Turkey

⁶Institute of Research and Development, Duy Tan University, Da Nang 550000, Viet Nam

⁷Department of Chemistry, College of Science, King Khalid University, P.O. Box 9004, 61413 Abha, Saudi Arabia

(Received December 21, 2021, Revised July 23, 2024, Accepted July 39, 2024)

Abstract. In the era of smart manufacturing, precise prediction of springback—a common issue in ultra-thin sheet metal forming—and forming limits are critical for ensuring high-quality production and minimizing waste. This paper presents a novel approach that leverages the Internet of Things (IoT) and Artificial Neural Networks (ANN) to enhance springback and forming limits prediction accuracy. By integrating IoT-enabled sensors and devices, real-time data on material properties, forming conditions, and environmental factors are collected and transmitted to a central processing unit. This data serves as the input for an ANN model, which is trained with crystal plasticity simulations and experimental data to predict springback with high precision. Our proposed system not only provides continuous monitoring and adaptive learning capabilities but also facilitates real-time decision-making in manufacturing processes. Experimental results demonstrate significant improvements in prediction accuracy compared to traditional methods, highlighting the potential of IoT and ANN integration in advancing smart manufacturing. This approach promises to revolutionize quality control and operational efficiency in the industry, paving the way for more intelligent and responsive manufacturing systems.

Keywords: ANFIS model; crystal plasticity; forming limit; IoT; neural-fuzzy AI system; springback; ultrathin sheets

1. Introduction

In the realm of modern manufacturing, the integration of sensors into the sheet forming process represents a significant advancement, enhancing both efficiency and precision (Dai *et al.* 2023a, b, Gu *et al.* 2023, Li *et al.* 2023a, Peng *et al.* 2023, Sabzevari *et al.* 2023, Shariati *et al.* 2023, Xiang *et al.* 2023, Yang *et al.* 2023, Zhang *et al.* 2023a, b, Zhao *et al.* 2023, Zheng *et al.* 2023). By embedding sensors within the machinery and materials, manufacturers can continuously monitor critical parameters such as pressure, temperature, strain, and material flow in real-time (Habibi *et al.* 2016, 2018a, b, 2019b, d, e, Ebrahimi *et al.* 2019a, Esmailpoor Hajilak *et al.* 2019, Pourjabari *et al.* 2019, Safarpour *et al.* 2019a, Zhu *et al.* 2022b, Dai *et al.* 2023b, Lu *et al.* 2023a, b, Ma *et al.* 2023, Tang *et al.* 2023, Wang *et al.* 2023, Zheng *et al.* 2023). This data-driven approach allows for immediate adjustments, reducing defects and ensuring consistent product quality. Furthermore, the use of sensors facilitates predictive maintenance, minimizing downtime and extending the lifespan of equipment (Seleznev *et al.* 2009, Shi *et al.* 2011,

Wolbring and Leopatra 2013, Kim *et al.* 2017).

Ultrasonic testing can be used to determine grain size in sheets. Ultrasonic testing is a non-destructive evaluation technique that uses high-frequency sound waves to inspect materials and detect various properties, including grain size and thickness of the sheet metals (Shariati *et al.* 2012, 2016a, b, 2019, 2020d, e, f, g, h, i, j, 2021a, b, Fan *et al.* 2022, Luo *et al.* 2022, Wang *et al.* 2022, Xia *et al.* 2022, Zhu *et al.* 2022a, Ghasemi and Vanini 2023).

Grain size has a significant impact on the springback phenomenon in metal forming processes (Fazaeli *et al.* 2016, Habibi *et al.* 2017, 2019a, c, Safarpour *et al.* 2018, 2019b, Amelirad and Assempour 2019, Alipour *et al.* 2020, Ebrahimi *et al.* 2020a, Ghazanfari *et al.* 2020, Safarpour *et al.* 2020, Amelirad and Assempour 2021, Chen *et al.* 2022). Springback refers to the elastic recovery of the metal after the forming forces are removed, causing the material to deviate from its intended shape. Fine-grained materials typically exhibit higher yield strength and better formability, which can reduce the extent of springback because the material's higher strength provides greater resistance to elastic deformation (Gau *et al.* 2007, Li *et al.* 2010, Kim *et al.* 2011, Liu *et al.* 2011). Conversely, coarse-grained metals tend to have lower yield strength and increased elastic recovery, leading to more pronounced springback. Additionally, fine-grained structures can improve the uniformity of deformation, leading to more predictable

*Corresponding author, Ph.D.,
E-mail: wanlichun111@163.com

and consistent springback behavior. Understanding and controlling grain size is therefore crucial in optimizing metal forming processes to minimize springback and achieve precise dimensional accuracy in the final product (Ebrahimi *et al.* 2019b, c, 2020b, Hashemi *et al.* 2019, Moayedi *et al.* 2019, 2020a, 2020b, Mohammadgholiha *et al.* 2019, Mohammadi *et al.* 2019, Adzima *et al.* 2020, Habibi *et al.* 2020, Oyarhossein *et al.* 2020, Shariati *et al.* 2020a, b, Shokrgozar *et al.* 2020, Guo *et al.* 2022).

The evaluation of springback using crystal plasticity involves modeling the behavior of individual grains within a polycrystalline metal during and after deformation (Xu *et al.* 2018, Wang *et al.* 2019, Adzima *et al.* 2020). Crystal plasticity accounts for the anisotropic nature of grain deformation and the interactions between grains, providing a detailed understanding of how microscopic mechanisms contribute to macroscopic springback. By incorporating factors such as grain orientation, slip systems, and hardening behavior, crystal plasticity simulations can predict the extent and distribution of springback more accurately than traditional continuum models (Dai *et al.* 2023b, Gu *et al.* 2023, Li *et al.* 2023a, Lu *et al.* 2023a, b, Ma *et al.* 2023, Peng *et al.* 2023, Sabzevari *et al.* 2023, Shariati *et al.* 2023, Tang *et al.* 2023, Wang *et al.* 2023, Yang *et al.* 2023, Zhang *et al.* 2023a, b, c, Zhao *et al.* 2023, Zheng *et al.* 2023, Guo *et al.* 2024, Liang *et al.* 2024, Song *et al.* 2024, Xiao *et al.* 2024, Yin *et al.* 2024, Yu *et al.* 2024, Zhang *et al.* 2024a, Zhang *et al.* 2024b, Zisong and Habibi 2024a). This detailed approach allows for better optimization of forming processes and material properties to minimize springback and achieve precise dimensional control in metal parts (Li *et al.* 2023b, 2024, Wu *et al.* 2023, Zisong and Habibi 2024b, Zisong and Habibi 2024a).

The application of Artificial Neural Networks (ANN) in predicting springback in sheet metals leverages the real-time data collected from in situ sensors during the forming process (Jang 1993, Esfahani *et al.* 2016, Xie *et al.* 2022). ANNs, with their ability to model complex nonlinear relationships, can analyze large datasets from sensors measuring parameters such as force, temperature, strain, and displacement (Hashemi *et al.* 2019, Al-Furjan *et al.* 2020e, o, q, s, Bai *et al.* 2020, Cheshmeh *et al.* 2020, Li *et al.* 2020a, Lori *et al.* 2020, Najaafi *et al.* 2020, Shariati *et al.* 2020c, Xiong *et al.* 2020, Guo *et al.* 2021b, Liu *et al.* 2021a, Tang *et al.* 2023, Huang *et al.* 2024, Wang *et al.* 2024, Zhiqiang *et al.* 2024). By training the ANN on historical data, where the input sensor readings are correlated with measured springback outcomes, the model learns to predict the springback behavior of new sheet metal parts under similar conditions (Jia *et al.* 2009, Elangovan *et al.* 2010, Derogar and Djavanroodi 2011). This predictive capability allows for immediate adjustments during the forming process, enhancing precision and reducing trial-and-error in achieving desired geometries. Consequently, using ANN in conjunction with in situ sensor data streamlines the production process, improves accuracy, and reduces material waste and production costs (Mohamed *et al.* 2016, Jiang *et al.* 2017, Adamović *et al.* 2018, Hirasawa *et al.* 2018, Adamian *et al.* 2020, Al-Furjan *et al.* 2020c, d, Li *et al.* 2020b, Liu *et al.* 2020a, b, 2021b, Wang *et al.*

2020, Zare *et al.* 2020, Zhou *et al.* 2020, Dai *et al.* 2021a, b, Guo *et al.* 2021a, Habibi *et al.* 2021, He *et al.* 2021, Huang *et al.* 2021, Shao *et al.* 2021, Wu and Habibi 2021, Zhang *et al.* 2021, Kong *et al.* 2022). Coupling the Internet of Things (IoT) with Artificial Neural Networks (ANN) in sheet metal forming brings a transformative approach to manufacturing, enabling intelligent and adaptive process control. IoT facilitates the collection of vast amounts of real-time data from an array of in situ sensors monitoring variables such as force, temperature, strain, and material thickness (Tzounis *et al.* 2017, Al-Furjan *et al.* 2020a, b, g, f, h, i, j, k, l, m, n, p, r, t, u, v, 2021a, b, Li and Niu 2020, Ghosh *et al.* 2021). This continuous data stream is fed into ANNs, which are trained to recognize patterns and predict outcomes like springback behavior. By analyzing this sensor data, ANNs can provide actionable insights and precise predictions, allowing for immediate adjustments to the forming process. This integration enhances process efficiency, reduces defects, and ensures consistent quality by dynamically adapting to variations in real time. Furthermore, the IoT-ANN synergy supports predictive maintenance and process optimization, driving innovation and competitiveness in the manufacturing sector.

In the current study, we present a novel approach that leverages the Internet of Things (IoT) and Artificial Neural Networks (ANN) to enhance springback prediction accuracy (Tian *et al.* 2022, Zhao *et al.* 2022, Xu *et al.* 2023b). By integrating IoT-enabled sensors and devices, real-time data on material properties, forming conditions, and environmental factors are collected and transmitted to a central processing unit. This data serves as the input for an ANN model, which is trained with crystal plasticity simulations and experimental data to predict springback with high precision (Zhang *et al.* 2022, Long *et al.* 2023, 2024). Our proposed system not only provides continuous monitoring and adaptive learning capabilities but also facilitates real-time decision-making in manufacturing processes. Experimental results demonstrate significant improvements in prediction accuracy compared to traditional methods, highlighting the potential of IoT and ANN integration in advancing smart manufacturing. This approach promises to revolutionize quality control and operational efficiency in the industry, paving the way for more intelligent and responsive manufacturing systems (Liu *et al.* 2024)

1.1 Gathering forming data using IoT

In the current study, an ultrasonic system is utilized to determine the thickness and grain size of the sheet. Using this device, the thickness of the sheet could be measured with an acceptable accuracy up to 0.001mm. However, the measurement of the grain size is not accurate and indeed it is not required to be determined exactly and only a description of fine, coarse and medium grain size should be sufficient for the type of analyses we are conducting in this study.

In addition, effect of temperature on the sheet forming and springback is reported in various studies. Therefore, a temperature sensor is added to the forming system to

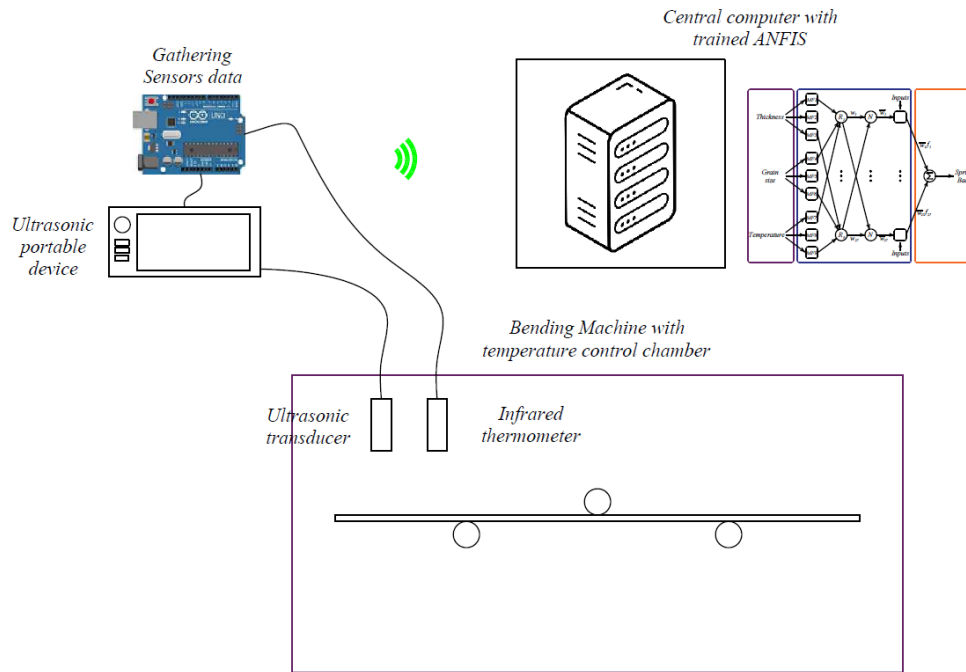

Fig. 1 IoT system with thermal and ultrasonic sensors

Table 1 Chemical Composition of St14 Steel Sheet

Fe	W	Cu	Ti	V	Mo	Cr
Rem.	0.039	0.053	0.001	0.006	0.026	0.049
Ni	Mn	P	S	Si	C	Ni
0.052	0.214	0.021	0.028a	0.031	0.03	0.052

measure the temperature. One another sensor used in the IoT system is the hardness measurement which is performed by automatic online devices. A schematic diagram and position of the three different sensors are depicted in Fig. 1. The collected data from the sensors are collected and send to central processing computer for further decision making about the spring back amount and the punch movement to achieve a desirable springback and final part angle according to tolerances.

2. Experimental setup

2.1 Material

This study uses St14 sheets with a thickness of 0.5 ± 0.02 mm to investigate formability under various rolling conditions. The chemical composition of the sheets is detailed in Table 1.

2.2 Heat treatment

To mitigate the effects of previous processing, the received sheets underwent heat treatment. The treatment was carried out at 900°C to 1000°C , with the sheets held at this temperature for 1 to 6 hours. The specimen was then cooled to room temperature in the furnace. This process

produces a more homogeneous microstructure with different grain sizes. In Table 2, the grain sizes produced from Ultrasonic measurement.

2.3 Metallography

The microstructure of St14 steel was examined using metallographic procedures. Samples from the heat-treated sheets were cut along the rolling direction, and sections were mounted. The samples were then ground with sandpaper up to 3000 grit and polished with $1\mu\text{m}$ diamond paste. To reveal the grain structure, a 2% Nital solution was used. The results are illustrated in Fig. 2 for the as-received samples and in Fig. 2 for the treated samples.

As shown in Fig. 2, the grains are spherical after heat treatment and the grains increased in size, with increase in the soaking temperature and time. The grains became spherical, and the spheroidized cementite decreases in amount, indicating significant decarburization in the furnace's oxygen atmosphere.

The detailed presentation of the microstructure is crucial due to its significant impact on springback. Even with similar thickness and chemical composition, variations in grain morphology can result in vastly different formability. For future studies, it is essential to report the mechanical and metallurgical properties of the sheet, as well as the testing conditions, to ensure comprehensive comparisons.

2.4 3-point bending

The three-point bending test provides valuable insights into the mechanical properties of sheet metals, which are essential for applications involving bending and flexural loads, such as in automotive, aerospace, and construction

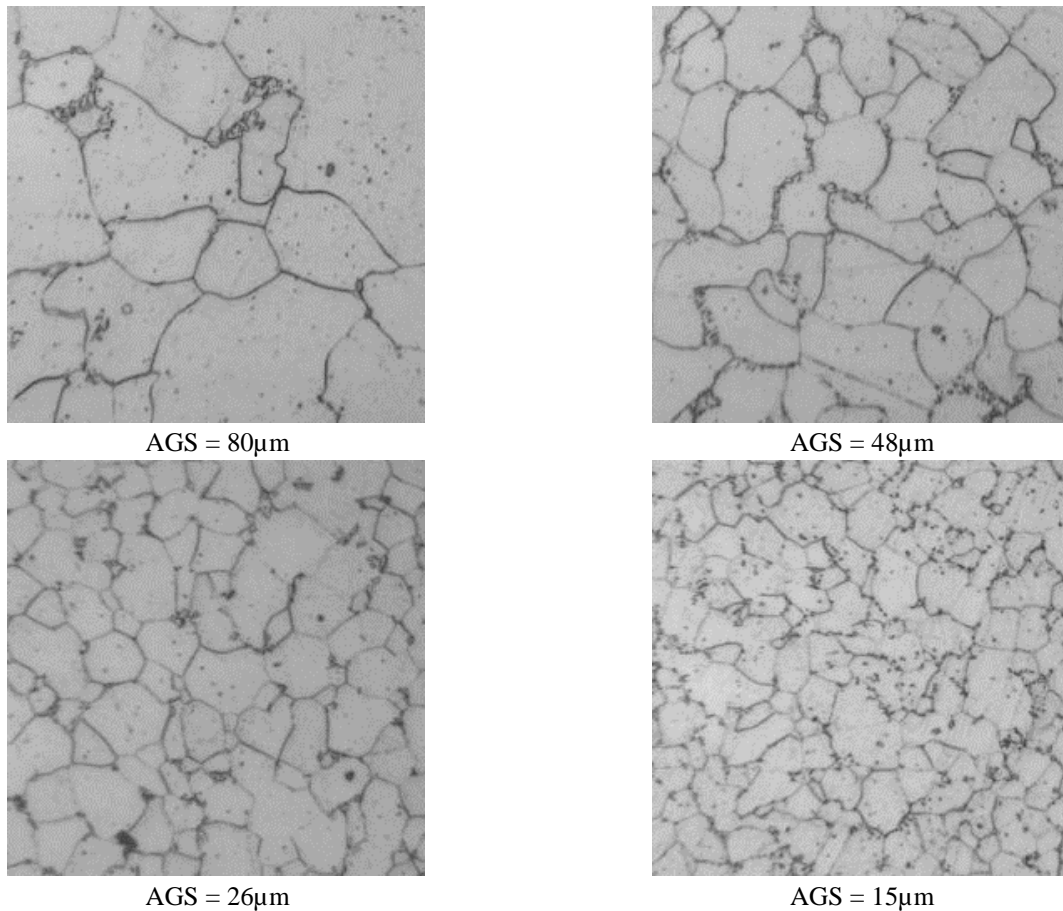

Fig. 2 Grain structure of the heat treated specimen in different soaking temperature and time. (A) 1000°C – 6hrs, (B) 1000°C – 2hrs, (C) 900°C – 6hrs and (D) 900°C – 2hrs

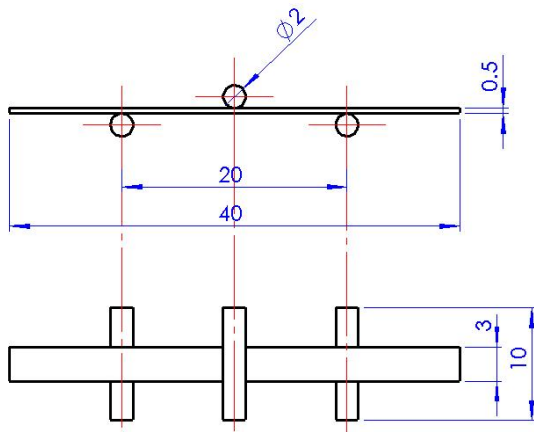

Fig. 3 Dimensions of the sheet, and bending punch and supports

industries. It helps in material selection, quality control, and in the design of components to ensure they can withstand operational stresses. In a three-point bending test for 0.5 mm thick St14 steel sheets, certain dimensions are crucial according to ASTM standards. For sheet metals, ASTM E290 is commonly referred to for bend testing of metallic materials. The important dimensions and parameters to consider are as follows.

Thickness (t): 0.5 mm

Width (b): 2 mm (10 times the thickness)

Length (L): 40 mm (considering a span of 20 mm plus extra length for secure placement)

Span Length (L): 20 mm (40 times the thickness, allowing for practical testing conditions)

Support Radius ($R1$): 1 mm

Loading Nose Radius ($R2$): 1 mm

These dimensions ensure that the test adheres to the ASTM standards, providing reliable and consistent results. The schematic setup is shown in Fig. 3.

2.5 Thickness measurement

Ultrasonic thickness measurement is a widely used non-destructive testing (NDT) technique for determining the thickness of materials. This method employs high-frequency sound waves to measure the thickness of a wide range of materials, including metals, plastics, composites, and ceramics. Thickness measurement is based on the time it takes for an ultrasonic pulse to travel through a material and reflect back from the opposite surface. We utilized a portable ultrasonic device from Krautkramer with a 5MHz transducer to measure the thickness of the sheet prior to the bending test. The device measures the time taken for the round trip of the ultrasonic pulse and calculates the thickness based on the speed of sound in the material.

The device was calibrated using a sample of 2 ± 0.001 mm thickness or using calibration blocks. Calibration ensures accurate measurements by accounting for the specific speed of sound in the material being tested. Water utilized as couplant in the current study and it is applied between the transducer and the sheet surface to eliminate air gaps and ensure efficient transmission of ultrasonic waves.

Advantages of this test could be categorized in its accuracy and nondestructive nature of the test. Similarly, the measurement could be rapidly conducted and reported using connection devices similar to Wi-Fi or data cables. On the other hand, surface condition like rough, corroded, or coated surfaces may affect the accuracy of measurements. The sound velocity in steel sheets with slightly different chemical and stiffness properties could be varied. Also, automatic thickness measurement may be affected by improper application of the water couplant.

2.6 Grain size measurement

The ultrasonic wave velocity and attenuation are influenced by the grain size, allowing the determination of grain structure through analysis of the returned signal. By comparing the measured data with metallography data, the average grain size can be estimated. This non-destructive technique provides valuable insights into the microstructure of steel sheets, which is crucial for understanding and predicting their mechanical properties and behavior in various applications.

2.7 Temperature measurement

The temperature of the sheet metal are varied from room temperature (50°C) to 250°C in a 50°C steps for the calibration of the model ANFIS model. These temperatures are measured using a calibrated infrared thermo-meter which could provide highly accurate data and transmit it through the designed IoT network.

3. Crystal plasticity simulation

For the simulation of the effects of the temperature and grain size on the springback of the St14 sheet metal, we utilize the MOOSE package (Shao *et al.* 2023, Xu *et al.* 2023a, Zhang *et al.* 2023). Using this package, it is possible to perform multiphysics simulations and it has a wide range of kernels for crystal plasticity simulations. This type of simulation could be integrated with the temperature kernel to obtain the response of material under different temperature and grain sizes. The main formulations of the crystal plasticity are detailed in (Amelirad and Assempour 2019). The same formulation is implemented in a MOOSE kernel for the aim of crystal plasticity simulations.

In the context of body-centered cubic (BCC) single crystals, the formulation for kinematics and constitutive equations involves understanding the crystal's response to deformation at the atomic level, particularly in terms of slip systems and their associated mechanisms. The total

deformation of a crystal is described by the deformation gradient tensor:

$$\mathbf{F} = \frac{\partial \mathbf{x}}{\partial \mathbf{X}} \quad (1)$$

where \mathbf{X} and \mathbf{x} are the reference and current coordinates, respectively. The deformation gradient can be multiplicatively decomposed into elastic and plastic parts:

$$\mathbf{F} = \mathbf{F}^e \mathbf{F}^p \quad (2)$$

3.1 Constitutive Equations for BCC Single Crystals

BCC crystals typically deform by slip along specific crystallographic planes and directions. The most common slip systems in BCC crystals are:

- Slip directions: $[111]$
- Slip planes: $(110), (112), (123)$

3.2 Schmid's Law

The resolved shear stress (τ^α) on a slip system (α) is given by Schmid's law:

$$\tau^\alpha = m^\alpha : \mathbf{T} \quad (3)$$

where m^α is the Schmid tensor for the slip system α , and \mathbf{T} is the Cauchy stress tensor.

3.3 Flow Rule

The plastic shear (Yuhua *et al.* 2017, Chen *et al.* 2020, Wang *et al.* 2024) rate ($\dot{\gamma}^\alpha$) for a slip system (α) is given by:

$$\dot{\gamma}^\alpha = \dot{\gamma}_0 \left(\frac{|\tau^\alpha|}{\tau_c^\alpha} \right)^m \text{sgn}(\tau^\alpha) \quad (4)$$

where, $\dot{\gamma}_0$ is reference shear rate, τ_c^α represents critical resolved shear stress for slip system α and m is the rate sensitivity exponent.

3.4 Hardening Law

The evolution of the critical resolved shear stress (τ_c^α) can be described by a hardening law:

$$\tau_c^\alpha = \sum_{\beta} h^{\alpha\beta} |\dot{\gamma}^\beta| \quad (5)$$

where ($h^{\alpha\beta}$) is the hardening matrix representing self and latent hardening effects between slip systems (α) and (β).

3.5 Kinematic Relations

The plastic part of the deformation gradient evolves as:

$$\mathbf{F}^p (\mathbf{F}^p)^{-1} = \sum_{\alpha} \dot{\gamma}^\alpha s^\alpha \otimes n^\alpha \quad (6)$$

In which, s^α is the slip direction vector for slip system (α) and n^α is the slip plane normal vector for slip system (α).

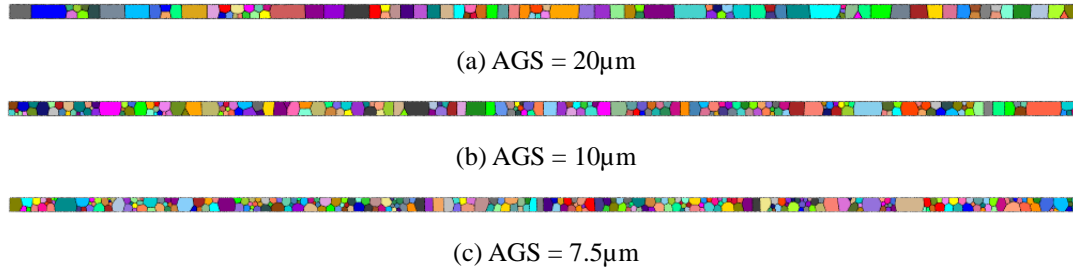

Fig. 4 Polycrystalline sheet models generated using Neper software

Elastic Constitutive Equations

The stress-strain relationship for the elastic part can be written as:

$$\mathbf{T} = \mathbb{C} : \mathbf{E}^e \quad (7)$$

In which, \mathbb{C} is the fourth-order elasticity tensor and \mathbf{E}^e : Elastic strain tensor, related to the elastic deformation gradient by:

$$\mathbf{E}^e = \frac{1}{2} [(\mathbf{F}^e)^T \mathbf{F}^e - \mathbf{I}] \quad (8)$$

These equations collectively describe the deformation behavior of BCC single crystals under various loading conditions.

3.6 Generating crystal structure using Neper

The model utilized here is a 2D sheet model generated using Neper package (Quey *et al.* 2011). Some examples of generated sheets are shown in Figure 4. The texture of all sheet models is considered to be random. These models are imported in the MOOSE software (Permann *et al.* 2020) and supports and punch has been added to it in the moose software.

4. ANFIS network setup

Adaptive Neuro-Fuzzy Inference System (ANFIS) is a powerful hybrid intelligent system that combines the learning capabilities of neural networks with the human-like reasoning style of fuzzy logic (Sabzevari *et al.* 2023). When applied to a problem where grain size, temperature, and thickness are inputs, and springback is the output, ANFIS can model the complex nonlinear relationships between these variables effectively. Here's how our ANFIS network can be configured for this application:

4.1 Inputs and Output

The inputs of the ANFIS network as depicted in Fig. 5 are the average size of grains in the metal sheet, which affects its mechanical properties, the processing or operating temperature, influencing the material's behavior during deformation and the thickness of the metal sheet, a crucial factor in its bending and springback characteristics. On the other side, the amount of elastic recovery that occurs when the sheet metal is unloaded after bending. It is a critical

parameter in metal forming processes as it affects the final shape of the part.

4.2 ANFIS Structure

As seen in Fig. 5 the structure of the ANFIS model consists of a fuzzification layer in which the input variables (grain size, temperature, and thickness) are fuzzified using appropriate membership functions. These could be Gaussian, triangular, or trapezoidal functions, depending on the nature of the input data and the desired level of granularity. For this application in current study we utilized Gaussian membership function. The Gaussian membership function is mathematically expressed as:

$$\mu(x) = \exp\left(-\frac{(x-c)^2}{2\sigma^2}\right) \quad (9)$$

where, $\mu(x)$ is the degree of membership of xxx in the fuzzy set, x is the input value, c is the mean (center) of the Gaussian curve and σ is the standard deviation, which controls the width of the Gaussian curve.

Subsequently, a set of fuzzy rules is established, typically of the form: If (Grain Size is Small) and (Temperature is High) and (Thickness is Thin), then (Springback is Low), If (Grain Size is Large) and (Temperature is Low) and (Thickness is Thick), then (Springback is High). These rules are based on expert knowledge or derived from data. In the next layer, the fuzzy inference system (usually a Mamdani or Sugeno type) processes the fuzzified inputs according to the fuzzy rules and generates fuzzy output sets. Finally, the fuzzy output sets are converted into a crisp output (springback value) using a defuzzification method like the centroid of area or weighted average.

4.3 Learning Algorithm

ANFIS uses a hybrid learning algorithm that combines gradient descent and least squares estimation to fine-tune the membership functions and optimize the fuzzy rules. During training, the network adjusts these parameters to minimize the error between predicted and actual springback values. Gathering experimental and verified simulation data on the effects of grain size, temperature, thickness, and corresponding springback values is the crucial and the most important step in the learning procedure. Without reliable data the ANFIS could provide inaccurate predictions.

For the purpose of training, a subset of the data is used

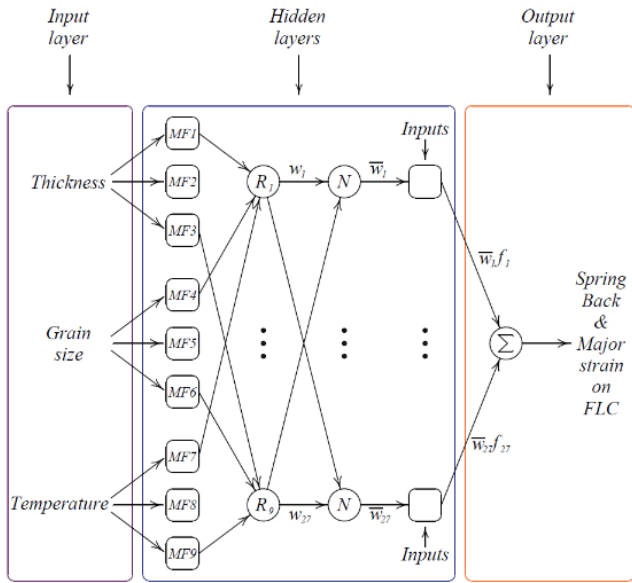

Fig. 5 The structure of ANFIS model for prediction of springback in sheet metals considering temperature, grain size and thickness as inputs

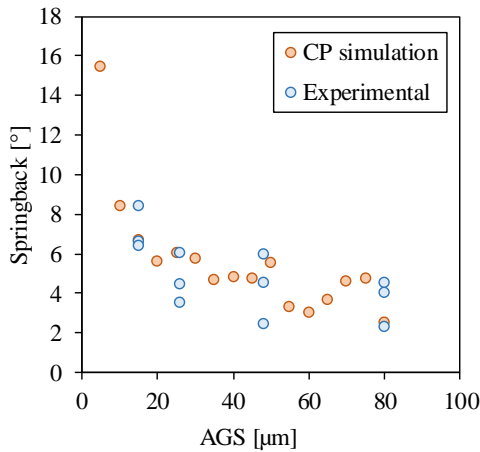

Fig. 6 Comparison of experimental results and crystal plasticity simulations in calculating spring back value

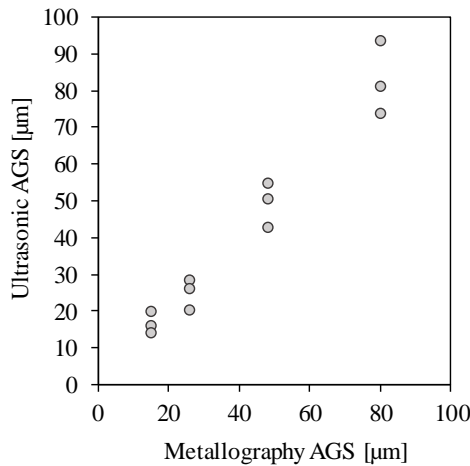

Fig. 7 Comparison of metallography and ultrasonic measurements of grain size in sheet specimen

the ANFIS model. The training process involves adjusting the parameters of the membership functions and rules to accurately map the inputs to the output. In the current study we used 70% of the initial data poll to train the ANFIS network. Next, the trained model using a separate subset of data (15%) to ensure it generalizes well to unseen data. Testing the network is performed using the remaining 15% of the data. After this step the ANFIS model may be used to predict springback for new combinations of grain size, temperature, and thickness.

One advantage of the ANFIS model is its ability to reflect the nonlinear relationships between inputs and springback values. In addition, the system can be trained and adjusted based on new data, making it flexible and adaptive to changes in material properties or processing conditions. Moreover, the fuzzy rules provide a transparent way to understand how different inputs affect the output, which is valuable for process optimization and decision-making. Using an ANFIS network to predict springback based on grain size, temperature, and thickness is a robust approach that leverages the strengths of both neural networks and fuzzy logic. It provides accurate predictions and valuable insights into the factors influencing springback, which are crucial for optimizing metal forming processes.

5. Results

5.1 Validation of the results

At the first step the results of the MOOSE should be compared to the experimental results. In this regard, the values of the hardening parameters should be calibrated to the St14 material in this study. For this purpose, the values of given in Ref. (Zisong and Habibi 2024b). The experimental procedure was to bend the specimen in room temperature to 120° angle and leave them to recover their elastic deformation. The angle of the specimen after the recovery was measured using image analysis in ImageJ software. The values of the spring back angle are given in Figure 6. This figure shows that the crystal plasticity simulations provides accurate results in comparison to the experimental data. Therefore, these results could be utilized in the training of the ANFIS network.

5.2 ANFIS training, validation and testing

In total, 184 number of simulations are performed in different grain size, thickness and temperature conditions. The training and validation error curves are depicted in Fig. 7. By error, we mean the mean squared error (MSE).

5.3 IoT data in comparison to actual measurements

In the current section, the grain size, thickness and temperature data collected from IoT system is compared to the actual values measured using metallography, micrometer, and contact thermocouple.

Fig. 8 shows the difference between metallography observation and ultrasonic measurements in determining grain size of the sheet metals. The correlation between these

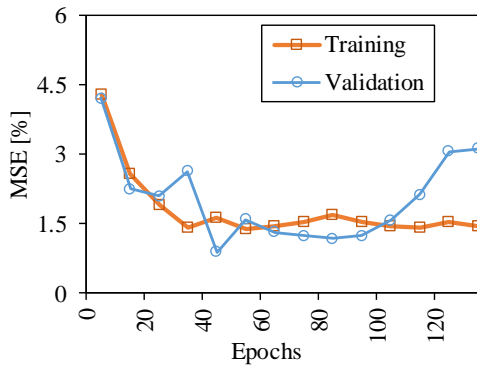

(a)

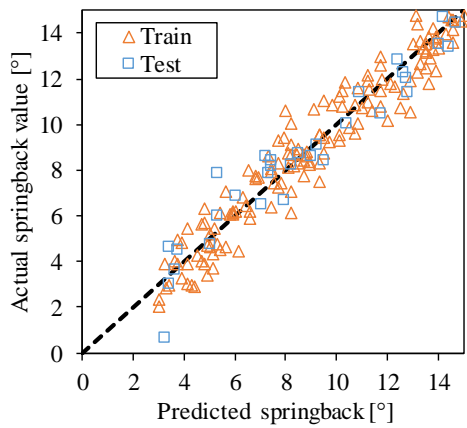

(b)

Fig. 8 (a) Training and validation error in the ANFIS model (b) values of springback as predicted by ANFIS in comparison to crystal plasticity simulations.

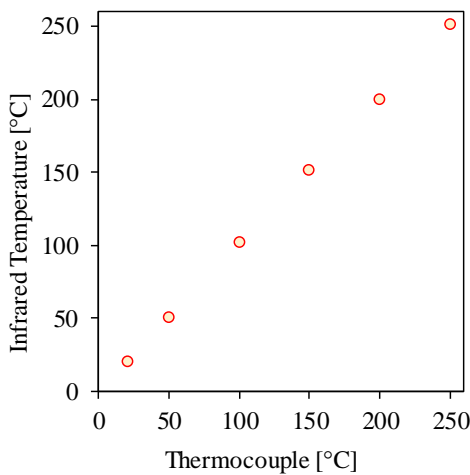

Fig. 9 Comparison of thermocouple and infrared laser measurements of temperature in sheet specimen

data are $R^2 = 0.97$ which extremely satisfactory for the type of application we have in this study.

Fig. 9 shows the difference between thermocouple and infrared measurements in determining temperature of the sheet metals. The correlation between these data are $R^2 = 1$ showing the correct measurement of temperature using infrared sensor.

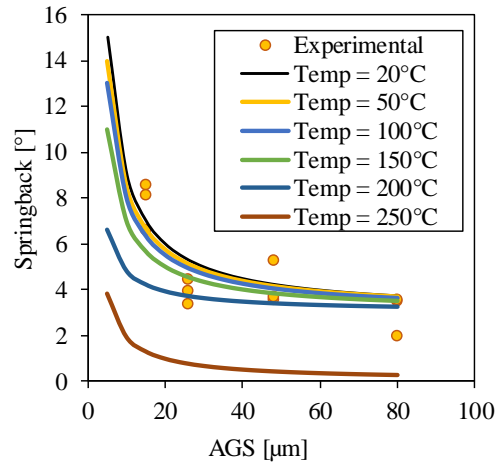

Fig. 10 Effects of temperature and grain size on the spring back of the St14 sheet metals

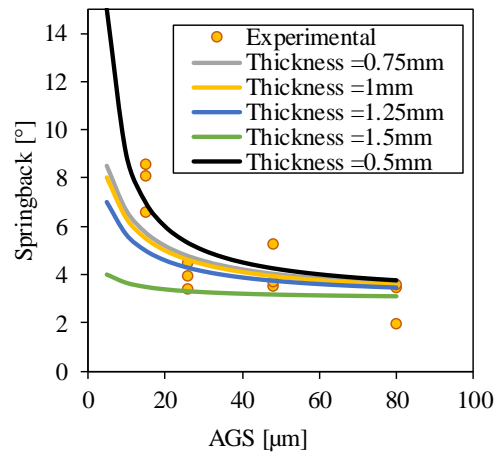

Fig. 11 Effects of thickness and grain size on the spring back of the St14 sheet metals

Table 2 Chemical Composition of St14 Steel Sheet

Micrometer measurement	Ultrasonic measurement
0.501	0.513
0.600	0.595
0.712	0.714
0.802	0.798
0.900	0.906
1.02	1.013
1.110	1.091
1.203	1.211
1.312	1.306
1.397	1.391
1.502	1.503

Table 2 shows the difference between micrometer and ultrasonic measurements in determining thickness of the sheet metals. The correlation between these data are $R^2 = 1$ showing the correct measurement of thickness using ultrasonic device.

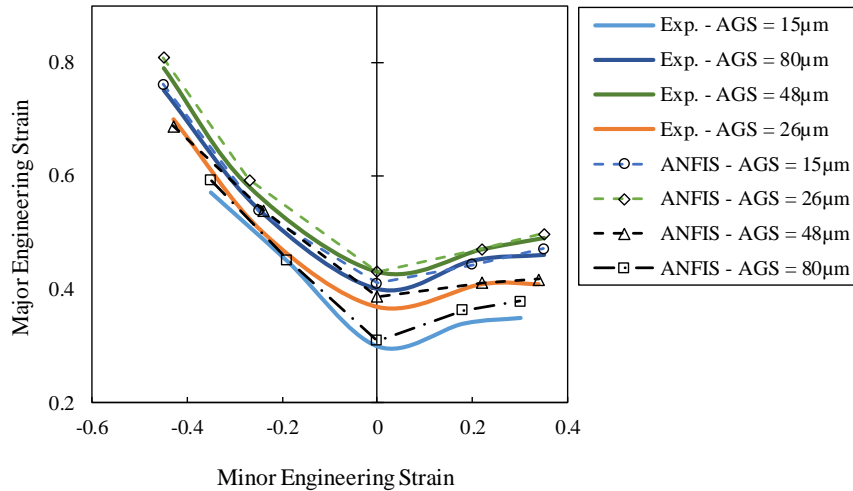

Fig. 12 Effects of grain size on the forming limit curves of the St14 sheet metals with thickness $t=0.5\text{mm}$

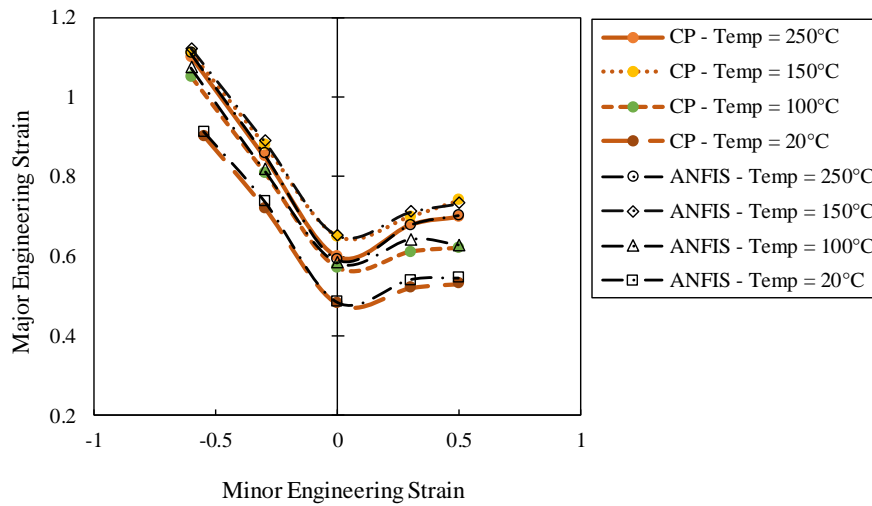

Fig. 13 Effects of temperature on the forming limit curves of the St14 sheet metals with thickness $t=0.5\text{mm}$

5.4 Parametric study

In this section, the predictions of ANFIS network in determining springback in St14 sheet metals are presented with changes in grain size, thickness and temperature. Fig. 10 shows the effects of temperature on the springback in sheet metals. The curves suggest that increase in the grain size decreases the spring back value as also shown by experimental results. In addition, increase in the temperature slightly decrease the spring back from 20 to 150°C and suddenly the effects become considerable above 200°C. The 250°C curve suggests slight effect of grain size on the spring back and the spring back diminishes in high temperatures.

Fig. 11 shows the effects of thickness on the springback in sheet metals. The curves suggest that increase in the grain size decreases the spring back value as also shown by experimental results. In addition, increase in the thickness decrease the spring back. At higher thickness of 1.5mm the springback is very low around 3.5° for all grain sizes.

The forming limit of the material are also influenced by the amount of thickness and forming temperature. Fig. 12

demonstrate the effect of grain size on the forming limit of the sheet metals. This figure shows that in this type of steel increase in the grain size improve the forming limits of the sheet. However, caution should be exercised for implementing these results in ultrafine and extremely coarse grain sizes.

The performance of the ANFIS network in determining effects of temperature on the forming limit are established in Figure 13. It is obvious that increase in the temperature increases the forming limits of the sheet. In addition, the trained ANFIS network shows satisfactory results in predicting forming limit curves (FLCs) of the St14 sheet metal with matching results with crystal plasticity simulations.

6. Conclusions

In the era of smart manufacturing, precise prediction of springback—a common issue in ultra-thin sheet metal forming—and forming limits are critical for ensuring high-quality production and minimizing waste. This paper

presents a novel approach that leverages the Internet of Things (IoT) and Artificial Neural Networks (ANN) to enhance springback prediction accuracy. By integrating IoT-enabled sensors and devices, real-time data on material properties, forming conditions, and environmental factors are collected and transmitted to a central processing unit. This data serves as the input for an ANN model, which is trained with crystal plasticity simulations and experimental data to predict springback with high precision. Our proposed system not only provides continuous monitoring and adaptive learning capabilities but also facilitates real-time decision-making in manufacturing processes. Experimental results demonstrate significant improvements in prediction accuracy compared to traditional methods, highlighting the potential of IoT and ANN integration in advancing smart manufacturing. This approach promises to revolutionize quality control and operational efficiency in the industry, paving the way for more intelligent and responsive manufacturing systems. The main results of the current study could be summarized in the following items:

- Increase in the temperature slightly decrease the spring back from 20 to 150°C and suddenly the effects become considerable above 200°C. The 250°C curve suggests slight effect of grain size on the spring back and the spring back diminishes in high temperatures.
- Increase in the grain size decreases the spring back value as also shown by experimental results.
- Increase in the thickness decrease the spring back. At higher thickness of 1.5mm the springback is very low around 3.5° for all grain sizes.
- Increase in the grain size improve the forming limits of the sheet. However, caution should be exercised for implementing these results in ultrafine and extremely coarse grain sizes.
- The trained ANFIS network shows satisfactory results in predicting forming limit curves (FLCs) of the St14 sheet metal with matching results with crystal plasticity simulations.

References

- Adamian, A., Safari, K.H., Sheikholeslami, M., Habibi, M., Al-Furjan, M. and Chen, G. (2020), "critical temperature and frequency characteristics of GPLs-reinforced composite doubly curved panel", *Appl. Sci.*, **10**(9), 3251. <https://doi.org/10.3390/app10093251>
- Adamović, V.M., Antanasijević, D.Z., Ristić, M.Đ., Perić-Grujić, A.A. and Pocajt, V.V. (2018), "An optimized artificial neural network model for the prediction of rate of hazardous chemical and healthcare waste generation at the national level", *J. Mater. Cycles Waste Manag.*, **20**(3), 1736-1750. <https://doi.org/10.1007/s10163-018-0741-6>
- Adzima, F., Balan, T. and Manach, P.Y. (2020), "Springback prediction for a mechanical micro connector using CPFEM based numerical simulations", *Int. J. Mater. Form.*, **13**(4), 649-659. <https://doi.org/10.1007/s12289-019-01503-5>
- Al-Furjan, M., Alzahrani, B., Shan, L., Habibi, M. and Jung, D.W. (2020a), "Nonlinear forced vibrations of nanocomposite-reinforced viscoelastic thick annular system under hygrothermal environment", *Mech. Based Des. Struct.*, 1-27. <https://doi.org/10.1080/15397734.2020.1824795>
- Al-Furjan, M., Bolandi, S.Y., Habibi, M., Ebrahimi, F., Chen, G. and Safarpour, H. (2021a), "Enhancing vibration performance of a spinning smart nanocomposite reinforced microstructure conveying fluid flow", *Eng. Comput.*, 1-16. <https://doi.org/10.1007/s00366-020-01255-w>
- Al-Furjan, M., Bolandi, S.Y., Shan, L., Habibi, M. and Jung, D.W. (2020b), "On the vibrations of a high-speed rotating multi-hybrid nanocomposite reinforced cantilevered microdisk", *Mech. Based Des. Struct.*, 1-29. <https://doi.org/10.1080/15397734.2020.1828098>
- Al-Furjan, M., Dehini, R., Khorami, M., Habibi, M. and won Jung, D. (2020c), "On the dynamics of the ultra-fast rotating cantilever orthotropic piezoelectric nanodisk based on nonlocal strain gradient theory", *Compos. Struct.*, 112990. <https://doi.org/10.1016/j.compstruct.2020.112990>
- Al-Furjan, M., Fereidouni, M., Habibi, M., Abd Ali, R., Ni, J. and Safarpour, M. (2020d), "Influence of in-plane loading on the vibrations of the fully symmetric mechanical systems via dynamic simulation and generalized differential quadrature framework", *Eng. Comput.*, 1-23. <https://doi.org/10.1007/s00366-020-01177-7>
- Al-Furjan, M., Fereidouni, M., Sedghiyan, D., Habibi, M. and won Jung, D. (2020e), "Three-dimensional frequency response of the CNT-Carbon-Fiber reinforced laminated circular/annular plates under initially stresses", *Compos. Struct.*, 113146. <https://doi.org/10.1016/j.compstruct.2020.113146>
- Al-Furjan, M., Habibi, M., Chen, G., Safarpour, H., Safarpour, M. and Tounsi, A. (2020f), "Chaotic oscillation of a multi-scale hybrid nano-composites reinforced disk under harmonic excitation via GDQM", *Compos. Struct.*, **252**, 112737. <https://doi.org/10.1016/j.compstruct.2020.112737>
- Al-Furjan, M., Habibi, M., Chen, G., Safarpour, H., Safarpour, M. and Tounsi, A. (2020g), "Chaotic simulation of the multi-phase reinforced thermo-elastic disk using GDQM", *Eng. Comput.*, 1-24. <https://doi.org/10.1007/s00366-023-01859-y>
- Al-Furjan, M., Habibi, M., Ebrahimi, F., Chen, G., Safarpour, M. and Safarpour, H. (2020h), "A coupled thermomechanics approach for frequency information of electrically composite microshell using heat-transfer continuum problem", *Eur. Phys. J. Plus*, **135**(10), 1-45. <https://doi.org/10.1140/epjp/s13360-020-00764-3>
- Al-Furjan, M., Habibi, M., Ebrahimi, F., Mohammadi, K. and Safarpour, H. (2020i), "Wave dispersion characteristics of high-speed-rotating laminated nanocomposite cylindrical shells based on four continuum mechanics theories", *Wave. Random Complex Med.*, 1-27. <https://doi.org/10.1080/17455030.2020.1831099>
- Al-Furjan, M., Habibi, M., Ni, J., won Jung, D. and Tounsi, A. (2020j), "Frequency simulation of viscoelastic multi-phase reinforced fully symmetric systems", *Eng. Comput.*, 1-17.
- Al-Furjan, M., Habibi, M. and Safarpour, H. (2020k), "Vibration control of a smart shell reinforced by graphene nanoplatelets", *Int. J. Appl. Mech.*, **12**(6), 2050066. <https://doi.org/10.1142/S1758825120500660>
- Al-Furjan, M., Habibi, M., Shan, L. and Tounsi, A. (2020l), "On the vibrations of the imperfect sandwich higher-order disk with a lactic core using generalize differential quadrature method", *Compos. Struct.*, 113150. <https://doi.org/10.1016/j.compstruct.2020.113150>
- Al-Furjan, M., Habibi, M., won Jung, D., Chen, G., Safarpour, M. and Safarpour, H. (2020m), "Chaotic responses and nonlinear dynamics of the graphene nanoplatelets reinforced doubly-curved panel", *Eur. J. Mech. A Solids*, **85** 104091. <https://doi.org/10.1016/j.euromechsol.2020.104091>
- Al-Furjan, M., Habibi, M., won Jung, D., Sadeghi, S., Safarpour, H., Tounsi, A. and Chen, G. (2020n), "A computational framework for propagated waves in a sandwich doubly curved

- nanocomposite panel”, *Eng. Comput.*, 1-18.
<https://doi.org/10.1007/s00366-020-01130-8>
- Al-Furjan, M., Habibi, M., won Jung, D. and Safarpour, H. (2020o), “Vibrational characteristics of a higher-order laminated composite viscoelastic annular microplate via modified couple stress theory”, *Compos. Struct.*, 113152.
<https://doi.org/10.1016/j.compstruct.2020.113152>
- Al-Furjan, M., Habibi, M., won Jung, D., Safarpour, H. and Safarpour, M. (2020p), “On the buckling of the polymer-CNT-fiber nanocomposite annular system under thermo-mechanical loads”, *Mech. Based Des. Struct.*, 1-21.
<https://doi.org/10.1080/15397734.2020.1830106>
- Al-Furjan, M., Moghadam, S.A., Dehini, R., Shan, L., Habibi, M. and Safarpour, H. (2020q), “Vibration control of a smart shell reinforced by graphene nanoplatelets under external load: Semi-numerical and finite element modeling”, *Thin Wall. Struct.*, 107242. <https://doi.org/10.1016/j.tws.2020.107242>
- Al-Furjan, M., Mohammadgholiha, M., Alarifi, I.M., Habibi, M. and Safarpour, H. (2020r), “On the phase velocity simulation of the multi curved viscoelastic system via an exact solution framework”, *Eng. Comput.*, 1-17.
<https://doi.org/10.1007/s00366-020-01152-2>
- Al-Furjan, M., Oyarhossein, M.A., Habibi, M., Safarpour, H. and Jung, D.W. (2020s), “Frequency and critical angular velocity characteristics of rotary laminated cantilever microdisk via two-dimensional analysis”, *Thin Wall. Struct.*, **157**, 107111.
<https://doi.org/10.1016/j.tws.2020.107111>
- Al-Furjan, M., Oyarhossein, M.A., Habibi, M., Safarpour, H. and Jung, D.W. (2020t), “Wave propagation simulation in an electrically open shell reinforced with multi-phase nanocomposites”, *Eng. Comput.*, 1-17.
<https://doi.org/10.1007/s00366-020-01167-9>
- Al-Furjan, M., Oyarhossein, M.A., Habibi, M., Safarpour, H., Jung, D.W. and Tounsi, A. (2020u), “On the wave propagation of the multi-scale hybrid nanocomposite doubly curved viscoelastic panel”, *Compos. Struct.*, 112947.
<https://doi.org/10.1016/j.compstruct.2020.112947>
- Al-Furjan, M., Safarpour, H., Habibi, M., Safarpour, M. and Tounsi, A. (2020v), “A comprehensive computational approach for nonlinear thermal instability of the electrically FG-GPLRC disk based on GDQ method”, *Eng. Comput.*, 1-18.
<https://doi.org/10.1007/s00366-020-01088-7>
- Al-Furjan, M.S.H., Dehini, R., Paknahad, M., Habibi, M. and Safarpour, H. (2021b), “On the nonlinear dynamics of the multi-scale hybrid nanocomposite-reinforced annular plate under hygro-thermal environment”, *Arch. Civil Mech. Eng.*, **21**(1), 4.
<https://doi.org/10.1007/s43452-020-00151-w>
- Alipour, M., Torabi, M.A., Sareban, M., Lashini, H., Sadeghi, E., Fazaali, A., Habibi, M. and Hashemi, R. (2020), “Finite element and experimental method for analyzing the effects of martensite morphologies on the formability of DP steels”, *Mech. Based Des. Struct.*, **48**(5), 525-541.
<https://doi.org/10.1080/15397734.2019.1633343>
- Amelirad, O. and Assempour, A. (2019), “Experimental and crystal plasticity evaluation of grain size effect on formability of austenitic stainless steel sheets”, *J. Manuf. Proc.*, **47**, 310-323.
<https://doi.org/10.1016/j.jmapro.2019.09.035>
- Amelirad, O. and Assempour, A. (2021), “Coupled continuum damage mechanics and crystal plasticity model and its application in damage evolution in polycrystalline aggregates”, *Eng. Comput.*, 1-15.
<https://doi.org/10.1007/s00366-021-01346-2>
- Bai, Y., Alzahrani, B., Baharom, S. and Habibi, M. (2020), “Semi-numerical simulation for vibrational responses of the viscoelastic imperfect annular system with honeycomb core under residual pressure”, *Eng. Comput.*, 1-26.
<https://doi.org/10.1007/s00366-020-01191-9>
- Chen, F., Chen, J., Duan, R., Habibi, M. and Khadimallah, M.A. (2022), “Investigation on dynamic stability and aeroelastic characteristics of composite curved pipes with any yawed angle”, *Compos. Struct.*, 115195.
<https://doi.org/10.1016/j.compstruct.2022.115195>
- Cheshmeh, E., Karbon, M., Eyvazian, A., Jung, D.w., Habibi, M. and Safarpour, M. (2020), “Buckling and vibration analysis of FG-CNTRC plate subjected to thermo-mechanical load based on higher order shear deformation theory”, *Mech. Based Des. Struct.*, 1-24.
<https://doi.org/10.1080/15397734.2020.1744005>
- Dai, Z., Jiang, Z., Zhang, L. and Habibi, M. (2021a), “Frequency characteristics and sensitivity analysis of a size-dependent laminated nanoshell”, *Adv. Nano Res.*, **10**(2), 175.
<https://doi.org/10.12989/anr.2021.10.2.175>
- Dai, Z., Tang, H., Wu, S., Habibi, M., Moradi, Z. and Ali, H.E. (2023a), “Nonlinear consecutive dynamic instabilities of thermally shocked composite circular plates on the softening elastic foundation”, *Thin Wall. Struct.*, **186**, 110645.
<https://doi.org/10.1016/j.tws.2023.110645>
- Dai, Z., Wu, S., Habibi, M. and Ali, H.E. (2023b), “Application of point interpolation mesh-free method for magneto/electro rheological vibrations of sandwich conical panels”, *Aerosp. Sci. Technol.*, 108180. <https://doi.org/10.1016/j.ast.2023.108180>
- Dai, Z., Zhang, L., Bolandi, S.Y. and Habibi, M. (2021b), “On the vibrations of the non-polynomial viscoelastic composite open-type shell under residual stresses”, *Compos. Struct.*, 113599.
<https://doi.org/10.1016/j.compstruct.2021.113599>
- Derogar, A. and Djavanroodi, F. (2011), “Artificial neural network modeling of forming limit diagram”, *Mater. Manuf. Proc.*, **26**(11), 1415-1422.
<https://doi.org/10.1080/10426914.2010.544818>
- Ebrahimi, F., Habibi, M. and Safarpour, H. (2019a), “On modeling of wave propagation in a thermally affected GNP-reinforced imperfect nanocomposite shell”, *Eng. Comput.*, **35**(4), 1375-1389. <https://doi.org/10.1007/s00366-018-0669-4>
- Ebrahimi, F., Hajilak, Z.E., Habibi, M. and Safarpour, H. (2019b), “Buckling and vibration characteristics of a carbon nanotube-reinforced spinning cantilever cylindrical 3D shell conveying viscous fluid flow and carrying spring-mass systems under various temperature distributions”, *Proceedings of the Institution of Mechanical Engineers, Part C: Journal of Mechanical Engineering Science*. **233**(13), 4590-4605.
<https://doi.org/10.1177/0954406219832323>
- Ebrahimi, F., Hashemabadi, D., Habibi, M. and Safarpour, H. (2020a), “Thermal buckling and forced vibration characteristics of a porous GNP reinforced nanocomposite cylindrical shell”, *Microsyst. Technol.*, **26**(2), 461-473.
<https://doi.org/10.1007/s00542-019-04542-9>
- Ebrahimi, F., Mohammadi, K., Barouti, M.M. and Habibi, M. (2019c), “Wave propagation analysis of a spinning porous graphene nanoplatelet-reinforced nanoshell”, *Wave. Random Complex Med.*, 1-27.
<https://doi.org/10.1080/17455030.2019.1694729>
- Ebrahimi, F., Supeni, E.E.B., Habibi, M. and Safarpour, H. (2020b), “Frequency characteristics of a GPL-reinforced composite microdisk coupled with a piezoelectric layer”, *Eur. Phys. J. Plus*, **135**(2), 144.
<https://doi.org/10.1140/epjp/s13360-020-00217-x>
- Elangovan, K., Sathiya Narayanan, C. and Narayanasamy, R. (2010), “Modelling of forming limit diagram of perforated commercial pure aluminium sheets using artificial neural network”, *Comput. Mater. Sci.*, **47**(4), 1072-1078.
<https://doi.org/10.1016/j.commatsci.2009.12.016>
- Esfahani, R.T., Golabi, S.i. and Zojaji, Z. (2016), “Optimization of finite element model of laser forming in circular path using genetic algorithms and ANFIS”, *Soft Comput.*, **20**(5), 2031-

2045. <https://doi.org/10.1007/s00500-015-1622-8>
- Esmailpoor Hajilak, Z., Pourghader, J., Hashemabadi, D., Sharifi Bagh, F., Habibi, M. and Safarpour, H. (2019), "Multilayer GPLRC composite cylindrical nanoshell using modified strain gradient theory", *Mech. Based Des. Struct.*, **47**(5), 521-545. <https://doi.org/10.1080/15397734.2019.1566743>
- Fan, L., Huang, Y., Ji, D., Moradi, Z., Safa, M. and Amine Khadimallah, M. (2022), "Interaction of angular velocity and temperature rise in the thermo-inertia bifurcation buckling of FG laminated nanocomposite annular plates", *Eng. Struct.*, **265**, 114518. <https://doi.org/10.1016/j.engstruct.2022.114518>
- Fazaeli, A., Habibi, M. and Ekrami, A.a. (2016), "Experimental and finite element comparison of mechanical properties and formability of dual phase steel and ferrite - pearlite steel with the same chemical composition", *Metall. Eng.*, **19**(2), 84-93. <http://doi.org/10.22076/me.2017.41458.1064>
- Gau, J.T., Principe, C. and Yu, M. (2007), "Springback behavior of brass in micro sheet forming", *J. Mater. Proc. Technol.*, **191**(1), 7-10. <https://doi.org/10.1016/j.jmatprotec.2007.03.035>
- Ghasemi, A. and Vanini, S.A.S. (2023), "Experimental and numerical investigation of martensite phase transformation in austenitic stainless steel subjected to ultrasonic nanocrystal surface modification at room and cryogenic temperatures", *Surf. Coat. Technol.*, **474**, 130109. <https://doi.org/10.1016/j.surfcoat.2023.130109>
- Ghazanfari, A., Soleimani, S.S., Keshavarzadeh, M., Habibi, M., Assempour, A. and Hashemi, R. (2020), "Prediction of FLD for sheet metal by considering through-thickness shear stresses", *Mech. Based Des. Struct.*, **48**(6), 755-772. <https://doi.org/10.1080/15397734.2019.1662310>
- Ghosh, T., Al Banna, M.H., Rahman, M.S., Kaiser, M.S., Mahmud, M., Hosen, A.S. and Cho, G.H. (2021), "Artificial intelligence and internet of things in screening and management of autism spectrum disorder", *Sust. Cities Soc.*, **74**, 103189. <https://doi.org/10.1016/j.scs.2021.103189>
- Gu, X., He, J., Wang, Z., Li, M., Habibi, M. and Hashemabadi, D. (2023), "Application of hyperbolic differential quadrature method for vibration responses of the electrorheological disk", *Eng. Anal. Bound. Elem.*, **155**, 599-615. <https://doi.org/10.1016/j.enganabound.2023.05.035>
- Guo, J., Baharvand, A., Tazeddinova, D., Habibi, M., Safarpour, H., Roco-Videla, A. and Selmi, A. (2021a), "An intelligent computer method for vibration responses of the spinning multi-layer symmetric nanosystem using multi-physics modeling", *Eng. Comput.*, 1-22. <https://doi.org/10.1007/s00366-021-01433-4>
- Guo, S., Tian, C., Pan, H., Tang, X., Han, L. and Wang, J. (2022), "Research on the springback behavior of 316L stainless steel in micro-scale bending processes", *Materials*, **15**(18), 6373. <https://doi.org/10.3390/ma15186373>
- Guo, Y., Maalla, A. and Habibi, M. (2024), "Electroelastic wave dispersion in the rotary piezoelectric NEMS sensors/actuators via nonlocal strain gradient theory", *Mech. Syst. Signal Proc.*, **216**, 111453. <https://doi.org/10.1016/j.ymsp.2024.111453>
- Guo, Y., Mi, H. and Habibi, M. (2021b), "Electromechanical energy absorption, resonance frequency, and low-velocity impact analysis of the piezoelectric doubly curved system", *Mech. Syst. Signal Proc.*, **157**, 107723. <https://doi.org/10.1016/j.ymsp.2021.107723>
- Habibi, M., Darabi, R., Sa, J.C.d. and Reis, A. (2021), "An innovation in finite element simulation via crystal plasticity assessment of grain morphology effect on sheet metal formability", *Proceedings of the Institution of Mechanical Engineers, Part L: Journal of Materials: Design and Applications*, **235**(8), 1937-1951. <https://doi.org/10.1177/14644207211024686>
- Habibi, M., Ghazanfari, A., Assempour, A., Naghdabadi, R. and Hashemi, R. (2017), "Determination of forming limit diagram using two modified finite element models", *Mech. Eng.*, **48**(4), 141-144. <https://doi.org/10.22060/MEJ.2016.664>
- Habibi, M., Hashemabadi, D. and Safarpour, H. (2019a), "Vibration analysis of a high-speed rotating GPLRC nanostructure coupled with a piezoelectric actuator", *Eur. Phys. J. Plus*, **134**(6), 307. <https://doi.org/10.1140/epjp/i2019-12742-7>
- Habibi, M., Hashemi, R., Ghazanfari, A., Naghdabadi, R. and Assempour, A. (2018a), "Forming limit diagrams by including the M-K model in finite element simulation considering the effect of bending", *Proceedings of the Institution of Mechanical Engineers, Part L: Journal of Materials: Design and Applications*, **232**(8), 625-636.
- Habibi, M., Hashemi, R., Sadeghi, E., Fazaeli, A., Ghazanfari, A. and Lashini, H. (2016), "Enhancing the mechanical properties and formability of low carbon steel with dual-phase microstructures", *J. Mater. Eng. Perform.*, **25**(2), 382-389. <https://doi.org/10.1007/s11665-016-1882-1>
- Habibi, M., Hashemi, R., Tafti, M.F. and Assempour, A. (2018b), "Experimental investigation of mechanical properties, formability and forming limit diagrams for tailor-welded blanks produced by friction stir welding", *J. Manuf. Proc.*, **31**, 310-323. <https://doi.org/10.1016/j.jmappro.2017.11.009>
- Habibi, M., Mohammadgholiha, M. and Safarpour, H. (2019b), "Wave propagation characteristics of the electrically GNP-reinforced nanocomposite cylindrical shell", *J. Brazil. Soc. Mech. Sci. Eng.*, **41**(5), 221. <https://doi.org/10.1007/s40430-019-1715-x>
- Habibi, M., Mohammadi, A., Safarpour, H. and Ghadiri, M. (2019c), "Effect of porosity on buckling and vibrational characteristics of the imperfect GPLRC composite nanoshell", *Mech. Based Des. Struct.*, 1-30. <https://doi.org/10.1080/15397734.2019.1701490>
- Habibi, M., Mohammadi, A., Safarpour, H., Shavalipour, A. and Ghadiri, M. (2019d), "Wave propagation analysis of the laminated cylindrical nanoshell coupled with a piezoelectric actuator", *Mech. Based Des. Struct.*, 1-19. <https://doi.org/10.1080/15397734.2019.1697932>
- Habibi, M., Safarpour, M. and Safarpour, H. (2020), "Vibrational characteristics of a FG-GPLRC viscoelastic thick annular plate using fourth-order Runge-Kutta and GDQ methods", *Mech. Based Des. Struct.*, 1-22. <https://doi.org/10.1080/15397734.2020.1779086>
- Habibi, M., Taghdir, A. and Safarpour, H. (2019e), "Stability analysis of an electrically cylindrical nanoshell reinforced with graphene nanoplatelets", *Compos. Part B Eng.*, **175**, 107125. <https://doi.org/10.1016/j.compositesb.2019.107125>
- Hashemi, H.R., Alizadeh, A.a., Oyarhossein, M.A., Shavalipour, A., Makkiabadi, M. and Habibi, M. (2019), "Influence of imperfection on amplitude and resonance frequency of a reinforcement compositionally graded nanostructure", *Wave. Random Complex Med.*, 1-27. <https://doi.org/10.1080/17455030.2019.1662968>
- He, X., Ding, J., Habibi, M., Safarpour, H. and Safarpour, M. (2021), "Non-polynomial framework for bending responses of the multi-scale hybrid laminated nanocomposite reinforced circular/annular plate", *Thin Wall. Struct.*, **166**, 108019. <https://doi.org/10.1016/j.tws.2021.108019>
- Hirasawa, T., Aoyama, K., Tanimoto, T., Ishihara, S., Shichijo, S., Ozawa, T., Ohnishi, T., Fujishiro, M., Matsuo, K., Fujisaki, J. and Tada, T. (2018), "Application of artificial intelligence using a convolutional neural network for detecting gastric cancer in endoscopic images", *Gastr. Cancer.*, **21**(4), 653-660. <https://doi.org/10.1007/s10120-018-0793-2>
- Huang, J., Pan, Z., Yang, S., Habibi, M. and Safa, M. (2024), "Bending-based solution methodology using eigenvalue-eigenvector approach for analysis of foldable reinforced Golf

- Clubs cylindrical shell”, *Mech. Adv. Mater. Struct.*, 1-14.
<https://doi.org/10.1080/15376494.2024.2378372>
- Huang, X., Hao, H., Oslub, K., Habibi, M. and Tounsi, A. (2021), “Dynamic stability/instability simulation of the rotary size-dependent functionally graded microsystem”, *Eng. Comput.*, 1-17. <https://doi.org/10.1007/s00366-021-01399-3>
- Jang, J.R. (1993), “ANFIS: adaptive-network-based fuzzy inference system”, *IEEE T Syst. Man Cybern.*, **23**(3), 665-685. <https://doi.org/10.1109/21.256541>
- Jia, D. “On the stretchability prediction of sheet metals using an artificial neural network based on experimental data”, *Wave. Random Complex Med.*, 1-19.
<https://doi.org/10.1080/17455030.2023.2178832>
- Jiang, F., Jiang, Y., Zhi, H., Dong, Y., Li, H., Ma, S., Wang, Y., Dong, Q., Shen, H. and Wang, Y. (2017), “Artificial intelligence in healthcare: past, present and future”, *Stroke Vasc. Neurol.*, **2**(4), 230-243. <https://doi.org/10.1136/svn-2017-000101>
- Kim, H., Lee, E., Kwon, D. and Ju, H. (2017). “Chemical laboratory safety management service using IoT sensors and open APIs”, *2017 International Conference on Information and Communications (ICIC)*, 26-28 June 2017.
- Kim, J., Lee, W., Chung, K.H., Kim, D., Kim, C., Okamoto, K., Wagoner, R.H. and Chung, K. (2011), “Springback evaluation of friction stir welded TWB automotive sheets”, *Metals Mater. Int.*, **17**(1), 83-98. <https://doi.org/10.1007/s12540-011-0212-2>
- Kong, F., Dong, F., Duan, M., Habibi, M., Safarpour, H. and Tounsi, A. (2022), “On the vibrations of the Electrorheological sandwich disk with composite face sheets considering pre and post-yield regions”, *Thin Wall. Struct.*, **179**, 109631. <https://doi.org/10.1016/j.tws.2022.109631>
- Li, A., Hu, W., Yang, Y., Li, K., Tian, H., Zhan, Z. and Meng, Q. (2024), “A microdamage model for FCC single crystals considering a mixed failure mechanism of slip and cleavage”, *Int. J. Plast.*, **173**, 103888. <https://doi.org/10.1016/j.ijplas.2024.103888>
- Li, C. and Niu, B. (2020), “Design of smart agriculture based on big data and Internet of things”, *Int. J. Distrib. Sensor Netw.*, **16**(5), 1550147720917065. <https://doi.org/10.1177/1550147720917065>
- Li, H., Dong, X., Shen, Y., Diehl, A., Hagenah, H., Engel, U. and Merklein, M. (2010), “Size effect on springback behavior due to plastic strain gradient hardening in microbending process of pure aluminum foils”, *Mater. Sci. Eng. A*, **527**(16), 4497-4504. <https://doi.org/10.1016/j.msea.2010.03.105>
- Li, J., Tang, F. and Habibi, M. (2020a), “Bi-directional thermal buckling and resonance frequency characteristics of a GNP-reinforced composite nanostructure”, *Eng. Comput.*, 1-22. <https://doi.org/10.1007/s00366-020-01110-y>
- Li, X., Li, M., Habibi, M., Najaafi, N. and Safarpour, H. (2023a), “Optimization of hybrid energy management system based on high-energy solid-state lithium batteries and reversible fuel cells”, *Energy*. **283** 128454. <https://doi.org/10.1016/j.energy.2023.128454>
- Li, Y., Li, S., Guo, K., Fang, X. and Habibi, M. (2020b), “On the modeling of bending responses of graphene-reinforced higher order annular plate via two-dimensional continuum mechanics approach”, *Eng. Comput.*, 1-22. <https://doi.org/10.1007/s00366-020-01166-w>
- Li, Y., Zhan, M., Jiang, X., Lei, Y. and Gao, P. (2023b), “Low-cycle fatigue behavior and life prediction of TA15 titanium alloy by crystal plasticity-based modelling”, *J. Mater. Res. Technol.*, **23**, 954-966. <https://doi.org/10.1016/j.jmrt.2023.01.063>
- Liang, Z., Zhao, Y., Yu, H., Habibi, M. and Mahmoudi, T. (2024). “Artificial neural networks coupled with numerical approach for the stability prediction of non-uniform functionally graded microscale cylindrical structures”, *Structures*, **60**, 105826. <https://doi.org/10.1016/j.istruc.2023.105826>
- Liu, H., Shen, S., Oslub, K., Habibi, M. and Safarpour, H. (2021a), “Amplitude motion and frequency simulation of a composite viscoelastic microsystem within modified couple stress elasticity”, *Eng. Comput.*, 1-15. <https://doi.org/10.1007/s00366-021-01316-8>
- Liu, H., Zhao, Y., Pishbin, M., Habibi, M., Bashir, M. and Issakhov, A. (2021b), “A comprehensive mathematical simulation of the composite size-dependent rotary 3D microsystem via two-dimensional generalized differential quadrature method”, *Eng. Comput.*, 1-16. <https://doi.org/10.1007/s00366-021-01419-2>
- Liu, J.G., Fu, M.W., Lu, J. and Chan, W.L. (2011), “Influence of size effect on the springback of sheet metal foils in micro-bending”, *Comput. Mater. Sci.*, **50**(9), 2604-2614. <https://doi.org/10.1016/j.commatsci.2011.04.002>
- Liu, Z., Su, S., Xi, D. and Habibi, M. (2020a), “Vibrational responses of a MHC viscoelastic thick annular plate in thermal environment using GDQ method”, *Mech. Based Des. Struct.*, 1-26. <https://doi.org/10.1080/15397734.2020.1784201>
- Liu, Z., Wu, X., Yu, M. and Habibi, M. (2020b), “Large-amplitude dynamical behavior of multilayer graphene platelets reinforced nanocomposite annular plate under thermo-mechanical loadings”, *Mech. Based Des. Struct.*, 1-25. <https://doi.org/10.1080/15397734.2020.1815544>
- Lori, E.S., Ebrahimi, F., Supeni, E.E.B., Habibi, M. and Safarpour, H. (2020), “The critical voltage of a GPL-reinforced composite microdisk covered with piezoelectric layer”, *Eng. Comput.*, 1-20. <https://doi.org/10.1007/s00366-020-01004-z>
- Lu, L., Liao, K., Habibi, M., Safarpour, H. and Ali, H.E. (2023a). “Numerical methods to predict aero thermally induced vibrations of a curved pipe structure reinforced by GPLs”, *Structures*, **55**, 1607-1621. <https://doi.org/10.1016/j.istruc.2023.06.105>
- Lu, S., Li, S., Habibi, M. and Safarpour, H. (2023b), “Improving the thermo-electro-mechanical responses of MEMS resonant accelerometers via a novel multi-layer perceptron neural network”, *Measurement*, 113168. <https://doi.org/10.1016/j.measurement.2023.113168>
- Luo, J., Wu, S., Hou, S., Moradi, Z., Habibi, M. and Khadimallah, M.A. (2022), “Thermally nonlinear thermoelasticity of a one-dimensional finite domain based on the finite strain concept”, *Eur. J. Mech. A Solids*, 104726. <https://doi.org/10.1016/j.euromechsol.2022.104726>
- Ma, B., Chen, K.-y., Habibi, M. and Albaijan, I. (2023), “Static/dynamic analyses of sandwich micro-plate based on modified strain gradient theory”, *Mech. Adv. Mater. Struct.*, 1-8. <https://doi.org/10.1080/15376494.2023.2219453>
- Moayed, H., Aliakbarlou, H., Jebeli, M., Noormohammadiarani, O., Habibi, M., Safarpour, H. and Foong, L. (2020a), “Thermal buckling responses of a graphene reinforced composite micropanel structure”, *Int. J. Appl. Mech.*, **12**(1), 2050010. <https://doi.org/10.1142/S1758825120500106>
- Moayed, H., Ebrahimi, F., Habibi, M., Safarpour, H. and Foong, L.K. (2020b), “Application of nonlocal strain-stress gradient theory and GDQEM for thermo-vibration responses of a laminated composite nanoshell”, *Eng. Comput.*, 1-16. <https://doi.org/10.1007/s00366-020-01002-1>
- Moayed, H., Habibi, M., Safarpour, H., Safarpour, M. and Foong, L. (2019), “Buckling and frequency responses of a graphene nanoplatelet reinforced composite microdisk”, *Int. J. Appl. Mech.*, **11**(10), 1950102. <https://doi.org/10.1142/S1758825119501023>
- Mohamed, M., Elatriby, S., Shi, Z. and Lin, J.G. (2016). “Prediction of forming limit diagram for AA5754 using artificial neural network modelling”, *Key Eng. Mater.*, **716**, 770-778.

- <https://doi.org/10.4028/www.scientific.net/KEM.716.770>
 Mohammadgholiha, M., Shokrgozar, A., Habibi, M. and Safarpour, H. (2019), "Buckling and frequency analysis of the nonlocal strain–stress gradient shell reinforced with graphene nanoplatelets", *J. Vib. Control*, **25**(19-20), 2627-2640.
<https://doi.org/10.1177/1077546319863251>
- Mohammadi, A., Lashini, H., Habibi, M. and Safarpour, H. (2019), "Influence of viscoelastic foundation on dynamic behaviour of the double walled cylindrical inhomogeneous micro shell using MCST and with the aid of GDQM", *J. Solid Mech.*, **11**(2), 440-453. <https://doi.org/10.22034/JSM.2019.665264>
- Najaafi, N., Jamali, M., Habibi, M., Sadeghi, S., Jung, D.w. and Nabipour, N. (2020), "Dynamic instability responses of the substructure living biological cells in the cytoplasm environment using stress-strain size-dependent theory", *J. Biomol. Struct. Dyn.*, 1-12.
<https://doi.org/10.1080/07391102.2020.1751297>
- Neil, C.J. and Agnew, S.R. (2009), "Crystal plasticity-based forming limit prediction for non-cubic metals: application to Mg alloy AZ31B", *Int. J. Plast.*, **25**(3), 379-398.
- Oyarhossein, M.A., Alizadeh, A.a., Habibi, M., Makkiabadi, M., Daman, M., Safarpour, H. and Jung, D.W. (2020), "Dynamic response of the nonlocal strain-stress gradient in laminated polymer composites microtubes", *Sci. Rep.*, **10**(1), 1-19.
<https://doi.org/10.1038/s41598-020-61855-w>
- Peng, S., Habibi, M. and Pourjabari, A. (2023), "Generalized differential quadrature element solution, swarm, and GA optimization technique to obtain the optimum frequency of the laminated rotary nanostructure", *Eng. Anal. Bound. Elem.*, **151**, 101-114. <https://doi.org/10.1016/j.enganabound.2023.02.052>
- Permann, C.J., Gaston, D.R., Andriš, D., Carlsen, R.W., Kong, F., Lindsay, A.D., Miller, J.M., Peterson, J.W., Slaughter, A.E., Stogner, R.H. and Martineau, R.C. (2020), "MOOSE: Enabling massively parallel multiphysics simulation", *SoftwareX*, **11**, 100430. <https://doi.org/10.1016/j.softx.2020.100430>
- Pourjabari, A., Hajilak, Z.E., Mohammadi, A., Habibi, M. and Safarpour, H. (2019), "Effect of porosity on free and forced vibration characteristics of the GPL reinforcement composite nanostructures", *Comput. Math. Appl.*, **77**(10), 2608-2626.
- Quey, R., Dawson, P.R. and Barbe, F. (2011), "Large-scale 3D random polycrystals for the finite element method: Generation, meshing and remeshing", *Comput. Meth. Appl. Mech. Eng.*, **200**(17), 1729-1745. <https://doi.org/10.1016/j.cma.2011.01.002>
- Sabzevari, F., Amelirad, O., Moradi, Z. and Habibi, M. (2023), "Artificial intelligence evaluation of COVID-19 restrictions and speech therapy effects on the autistic children's behavior", *Sci. Rep.*, **13**(1), 4312. <https://doi.org/10.1038/s41598-022-25902-y>
- Safarpour, H., Ghanizadeh, S.A. and Habibi, M. (2018), "Wave propagation characteristics of a cylindrical laminated composite nanoshell in thermal environment based on the nonlocal strain gradient theory", *Eur. Phys. J. Plus*, **133**(12), 532.
<https://doi.org/10.1140/epjp/i2018-12385-2>
- Safarpour, H., Hajilak, Z.E. and Habibi, M. (2019a), "A size-dependent exact theory for thermal buckling, free and forced vibration analysis of temperature dependent FG multilayer GPLRC composite nanostructures resting on elastic foundation", *Int. J. Mech. Mater. Des.*, **15**(3), 569-583.
<https://doi.org/10.1007/s10999-018-9431-8>
- Safarpour, H., Pourghader, J. and Habibi, M. (2019b), "Influence of spring-mass systems on frequency behavior and critical voltage of a high-speed rotating cantilever cylindrical three-dimensional shell coupled with piezoelectric actuator", *J. Vib. Control*, **25**(9), 1543-1557.
<https://doi.org/10.1177/1077546319828465>
- Safarpour, M., Ebrahimi, F., Habibi, M. and Safarpour, H. (2020), "On the nonlinear dynamics of a multi-scale hybrid nanocomposite disk", *Eng. Comput.*, 1-20.
<https://doi.org/10.1007/s00366-020-00949-5>
- Seleznnev, V.A., Prinz, V.Y., Aniskin, V.M. and Maslov, A.A. (2009), "Generation and registration of disturbances in a gas flow. 1. Formation of arrays of tubular microheaters and microsensors", *J. Appl. Mech. Tech. Phys.*, **50**(2), 291-296.
<https://doi.org/10.1007/s10808-009-0039-5>
- Shao, Y., Zhao, Y., Gao, J. and Habibi, M. (2021), "Energy absorption of the strengthened viscoelastic multi-curved composite panel under friction force", *Arch. Civil Mech. Eng.*, **21**(4), 1-29. <https://doi.org/10.1007/s43452-021-00279-3>
- Shariati, A., Habibi, M., Tounsi, A., Safarpour, H. and Safa, M. (2020a), "Application of exact continuum size-dependent theory for stability and frequency analysis of a curved cantilevered microtubule by considering viscoelastic properties", *Eng. Comput.*, 1-20. <https://doi.org/10.1007/s00366-020-01024-9>
- Shariati, A., Mohammad-Sedighi, H., Żur, K.K., Habibi, M. and Safa, M. (2020b), "On the vibrations and stability of moving viscoelastic axially functionally graded nanobeams", *Materials*. **13**(7), 1707. <https://doi.org/10.3390/ma13071707>
- Shariati, A., Mohammad-Sedighi, H., Żur, K.K., Habibi, M. and Safa, M. (2020c), "Stability and dynamics of viscoelastic moving rayleigh beams with an asymmetrical distribution of material parameters", *Symmetry*. **12**(4), 586.
<https://doi.org/10.3390/sym12040586>
- Shariati, M., Azar, S.M., Arjomand, M.-A., Tehrani, H.S., Daei, M. and Safa, M. (2020d), "Evaluating the impacts of using piles and geosynthetics in reducing the settlement of fine-grained soils under static load", *Geomech. Eng.*, **20**(2), 87-101.
<https://doi.org/10.12989/gae.2020.20.2.087>
- Shariati, M., Davoodnabi, S.M., Toghroli, A., Kong, Z. and Shariati, A. (2021a), "Hybridization of metaheuristic algorithms with adaptive neuro-fuzzy inference system to predict load-slip behavior of angle shear connectors at elevated temperatures", *Compos. Struct.*, 114524.
<https://doi.org/10.1016/j.compstruct.2021.114524>
- Shariati, M., Faegh, S.S., Mehrabi, P., Bahavarnia, S., Zandi, Y., Masoom, D.R., Toghroli, A., Trung, N.-T. and Salih, M.N. (2019), "Numerical study on the structural performance of corrugated low yield point steel plate shear walls with circular openings", *Steel Compos. Struct.*, **33**(4), 569-581.
<https://doi.org/10.12989/scs.2019.33.4.569>
- Shariati, M., Ghorbani, M., Naghipour, M., Alinejad, N. and Toghroli, A. (2020e), "The effect of RBS connection on energy absorption in tall buildings with braced tube frame system", *Steel Compos. Struct.*, **34**(3), 393-407.
<https://doi.org/10.12989/scs.2020.34.3.393>
- Shariati, M., Kamyab, H., Habibi, M., Ahmadi, S., Naghipour, M., Gorjinezhad, F., Mohammadirad, S. and Aminian, A. (2023), "Sulfuric acid resistance of concrete containing coal waste as a partial substitute for fine and coarse aggregates", *Fuel*, **348**, 128311. <https://doi.org/10.1016/j.fuel.2023.128311>
- Shariati, M., Lagzian, M., Maleki, S., Shariati, A. and Trung, N.T. (2020f), "Evaluation of seismic performance factors for tension-only braced frames", *Steel Compos. Struct.*, **35**(4), 599-609.
<https://doi.org/10.12989/scs.2020.35.4.599>
- Shariati, M., Mafipour, M.S., Ghahremani, B., Azarhomayun, F., Ahmadi, M., Trung, N.T. and Shariati, A. (2020g), "A novel hybrid extreme learning machine–grey wolf optimizer (ELM-GWO) model to predict compressive strength of concrete with partial replacements for cement", *Eng. Comput.*, 1-23.
<https://doi.org/10.1007/s00366-020-01081-0>
- Shariati, M., Mafipour, M.S., Mehrabi, P., Ahmadi, M., Wakil, K., Trung, N.T. and Toghroli, A. (2020h), "Prediction of concrete strength in presence of furnace slag and fly ash using Hybrid ANN-GA (Artificial Neural Network-Genetic Algorithm)", *Smart Struct. Syst.*, **25**(2), 183-195.
<https://doi.org/10.12989/sss.2020.25.2.183>

- Shariati, M., Naghipour, M., Yousofizinsaz, G., Toghroli, A. and Tabarestani, N.P. (2020), "Numerical study on the axial compressive behavior of built-up CFT columns considering different welding lines", *Steel Compos. Struct.* **34**(3), 377-391. <http://doi.org/10.12989/scs.2020.34.3.377>
- Shariati, M., Shariati, A., Trung, N.T., Shoaie, P., Ameri, F., Bahrami, N. and Zamanabadi, S.N. (2021b), "Alkali-activated slag (AAS) paste: Correlation between durability and micro-structural characteristics", *Constr. Build. Mater.*, **267**, 120886. <https://doi.org/10.1016/j.conbuildmat.2020.120886>
- Shariati, M., Sulong, N.R. and Khanouki, M.A. (2012), "Experimental assessment of channel shear connectors under monotonic and fully reversed cyclic loading in high strength concrete", *Mater. Des.*, **34**, 325-331. <https://doi.org/10.1016/j.matdes.2011.08.008>
- Shariati, M., Sulong, N.R., Shariati, A. and Khanouki, M.A. (2016a), "Behavior of V-shaped angle shear connectors: experimental and parametric study", *Mater. Struct.*, **49**(9), 3909-3926. <https://doi.org/10.1617/s11527-015-0762-8>
- Shariati, M., Sulong, N.R., Shariati, A. and Kueh, A. (2016b), "Comparative performance of channel and angle shear connectors in high strength concrete composites: An experimental study", *Constr. Build. Mater.*, **120**, 382-392. <https://doi.org/10.1016/j.conbuildmat.2016.05.102>
- Shariati, M., Tahmasbi, F., Mehrabi, P., Bahadori, A. and Toghroli, A. (2020j), "Monotonic behavior of C and L shaped angle shear connectors within steel-concrete composite beams: An experimental investigation", *Steel Compos Struct.* **35**(2), 237-247. <http://doi.org/10.12989/scs.2020.35.2.237>
- Shi, C.W.P., Shan, X., Tarapata, G., Jachowicz, R., Weremczuk, J. and Hui, H.T. (2011), "Fabrication of wireless sensors on flexible film using screen printing and via filling", *Microsyst. Technol.*, **17**(4), 661-667. <https://doi.org/10.1007/s00542-010-1161-2>
- Shokrgozar, A., Safarpour, H. and Habibi, M. (2020), "Influence of system parameters on buckling and frequency analysis of a spinning cantilever cylindrical 3D shell coupled with piezoelectric actuator", *Proceedings of the Institution of Mechanical Engineers, Part C: Journal of Mechanical Engineering Science.* **234**(2), 512-529. <https://doi.org/10.1177/0954406219883312>
- Song, G., Zou, Y., Nie, Y., Habibi, M., Albaijan, I. and Toghroli, E. (2024), "Application of Hashin-Shtrikman bounds homogenization model for frequency analysis of imperfect FG bio-composite plates", *J. Mech. Behav. Biomed. Mater.*, **151**, 106321. <https://doi.org/10.1016/j.jmbbm.2023.106321>
- Tang, J., Wu, S., Habibi, M., Safarpour, M. and Ali, H.E. (2023), "Flutter analysis of multi-directional functionally graded sector poroelastic disks", *Aerosp. Sci. Technol.*, **140**, 108481. <https://doi.org/10.1016/j.ast.2023.108481>
- Tzounis, A., Katsoulas, N., Bartzanas, T. and Kittas, C. (2017), "Internet of Things in agriculture, recent advances and future challenges", *Biosyst. Eng.*, **164**, 31-48. <https://doi.org/10.1016/j.biosystemseng.2017.09.007>
- Wang, C., Habibi, M. and Mahmoudi, T. (2024), "Stability analysis of the nonuniform functionally graded cylindrical small-scale beam structures: Application in sport structures", *Steel Compos. Struct.*, **52**(1), 15. <https://doi.org/10.12989/scs.2024.52.1.015>
- Wang, C., Wang, S., Wang, S., Chen, G. and Zhang, P. (2019), "Investigation on springback behavior of Cu/Ni clad foils during flexible die micro V-bending process", *Metals*, **9**(8), 892. <https://doi.org/10.3390/met9080892>
- Wang, H., Habibi, M., Marzouki, R., Majdi, A., Shariati, M., Denic, N., Zakić, A., Khorami, M., Khadimallah, M.A. and Ebid, A.A.K. (2022), "Improving the Self-Healing of Cementitious Materials with a Hydrogel System", *Gels*, **8**(5), 278. <https://doi.org/10.3390/gels8050278>
- Wang, Y., Jia, Q., Deng, T., Habibi, M., Al-Kikani, S. and Ali, H.E. (2023), "Wave propagation analysis of the ball in the handball's game", *Struct. Eng. Mech.*, **85**(6), 729-742.
- Wang, Z., Yu, S., Xiao, Z. and Habibi, M. (2020), "Frequency and buckling responses of a high-speed rotating fiber metal laminated cantilevered microdisk", *Mech. Adv. Mater. Struct.*, 1-14. <https://doi.org/10.1080/15376494.2020.1824284>
- Wolbring, G. and Leopatra, V. (2013), "Sensors: Views of staff of a disability service organization", *J. Person. Med.*, **3**(1), 23-39. <https://doi.org/10.3390/jpm3010023>
- Wu, H., Huang, T., Song, K., Zhang, Y., Zhou, Y., Li, S. and Li, X. (2023), "Study on deformation characteristics of multi-pass continuous drawing of micro copper wire based on crystal plasticity finite element method", *Nanotech. Rev.*, **12**(1). <https://doi.org/10.1515/ntrev-2023-0110>
- Wu, J. and Habibi, M. (2021), "Dynamic simulation of the ultra-fast-rotating sandwich cantilever disk via finite element and semi-numerical methods", *Eng. Comput.*, 1-17. <https://doi.org/10.1007/s00366-021-01396-6>
- Xia, W., Du, J., Habibi, M., Shariati, M. and Khadimallah, M.A. (2022), "Application of Chebyshev-based GDQ and Newmark methods to viscothermoelasticity responses of FG composite annular systems", *Eng. Anal. Bound. Elem.*, **143** 28-42. <https://doi.org/10.1016/j.enganabound.2022.06.003>
- Xiang, J., Lai, Y., Moradi, Z. and Khorami, M. (2023), "Wave propagation phenomenon of functionally graded graphene oxide powder-strengthened nanocomposite curved beam", *Solid State Commun.*, 115193. <https://doi.org/10.1016/j.ssc.2023.115193>
- Xiao, H., Habibi, M. and Habibi, M. (2024), "Bulk wave propagation analysis of imperfect FG bio-composite beams resting on variable elastic medium", *Mater. Today Commun.*, **39**, 108524. <https://doi.org/10.1016/j.mtcomm.2024.108524>
- Xie, Y., Wu, Y., Jalali, A., Zhou, H. and Amine Khadimallah, M. (2022), "Effects of thickness reduction in cold rolling process on the formability of sheet metals using ANFIS", *Sci. Rep.*, **12**(1), 10434. <https://doi.org/10.1038/s41598-022-13694-0>
- Xiong, Q.M., Chen, Z., Huang, J.T., Zhang, M., Song, H., Hou, X.F., Li, X.B. and Feng, Z.J. (2020), "Preparation, structure and mechanical properties of Sialon ceramics by transition metal-catalyzed nitriding reaction", *Rare Metals*. **39**(5), 589-596. <https://doi.org/10.1007/s12598-020-01385-6>
- Xu, Z., Peng, L. and Bao, E. (2018), "Size effect affected springback in micro/meso scale bending process: Experiments and numerical modeling", *J. Mater. Proc. Technol.*, **252**, 407-420. <https://doi.org/10.1016/j.jmatprotec.2017.08.040>
- Yang, C., Su, C., Hu, H., Habibi, M., Safarpour, H. and Khadimallah, M.A. (2023), "Performance optimization of photovoltaic and solar cells via a hybrid and efficient chimp algorithm", *Solar Energy*, **253**, 343-359. <https://doi.org/10.1016/j.solener.2023.02.036>
- Yin, J., Zou, Y., Li, J., Zhang, W., Li, X. and Habibi, M. (2024), "Dynamic stability and frequency responses of the tilted curved nanopipes in a supersonic airflow via 2D hybrid nonlocal strain gradient theory", *Eng. Struct.*, **301**, 117240. <https://doi.org/10.1016/j.engstruct.2023.117240>
- Yu, C., Lin, P., Wu, Z., Habibi, M. and Zhang, W. (2024), "Multi-load effect on the deformation analysis of composite nano reinforced origami sandwich panel", *Mech. Adv. Mater. Struct.*, 1-19. <https://doi.org/10.1080/15376494.2024.2367015>
- Zare, R., Najaafi, N., Habibi, M., Ebrahimi, F. and Safarpour, H. (2020), "Influence of imperfection on the smart control frequency characteristics of a cylindrical sensor-actuator GPLRC cylindrical shell using a proportional-derivative smart controller", *Smart Struct. Syst.*, **26**(4), 469-480. <https://doi.org/10.12989/sss.2020.26.4.469>
- Zhang, D., Huang, X., Wang, T., Habibi, M., Albaijan, I. and

- Togholi, E. (2024a), "Dynamic stability improvement in spinning FG-piezo cylindrical structure using PSO-ANN and firefly optimization algorithm", *Mater. Sci. Eng. B*, **302**, 117210. <https://doi.org/10.1016/j.mseb.2024.117210>
- Zhang, Q., Zou, X., Wang, Y. and Habibi, M. (2023a), "Study on photocatalytic, electric, and sensing behavior of Co-and Ag-codoped tin dioxide (SnO₂) nano particles", *Mater. Sci. Eng. B*, **296**, 116687. <https://doi.org/10.1016/j.mseb.2023.116687>
- Zhang, S., Lai, Y., Chen, K., Habibi, M., Khorami, M. and Haider Mussa, Z. (2023b), "Influence of MWCNT's waviness and aggregation factors on wave dispersion response of MWCNT-strengthened nanocomposite curved beam", *Structures*, **53**, 1239-1249. <https://doi.org/10.1016/j.istruc.2023.04.024>
- Zhang, X., Li, J., Cui, Y., Habibi, M., Ali, H.E., Albaijan, I. and Mahmoudi, T. (2023c), "Static analysis of 2D-FG nonlocal porous tube using gradient strain theory and based on the first and higher-order beam theory", *Steel Compos. Struct.*, **49**(3), 293-306. <https://doi.org/10.12989/scs.2023.49.3.293>
- Zhang, Y., Wang, Z., Tazeddinova, D., Ebrahimi, F., Habibi, M. and Safarpour, H. (2021), "Enhancing active vibration control performances in a smart rotary sandwich thick nanostructure conveying viscous fluid flow by a PD controller", *Wave. Random Complex Med.*, 1-24. <https://doi.org/10.1080/17455030.2021.1948627>
- Zhang, Y., Wang, Z., Tazeddinova, D., Ebrahimi, F., Habibi, M. and Safarpour, H. (2024b), "Enhancing active vibration control performances in a smart rotary sandwich thick nanostructure conveying viscous fluid flow by a PD controller", *Wave. Random Complex Med.*, **34**(3), 1835-1858. <https://doi.org/10.1080/17455030.2021.1948627>
- Zhao, H., Li, C., Fu, Y., Oyarhossein, M.A., Habibi, M. and Safarpour, H. (2023), "Quasi-static indentation, low-velocity impact, and resonance responses of the laminated double-curved panel considering various boundary conditions", *Thin Wall. Struct.*, **183**, 110360. <https://doi.org/10.1016/j.tws.2022.110360>
- Zheng, W., Liu, J., Oyarhossein, M.A., Safarpour, H. and Habibi, M. (2023), "Prediction of nth-order derivatives for vibration responses of a sandwich shell composed of a magneto-rheological core and composite face layers", *Eng. Anal. Bound. Elem.*, **146**, 170-183. <https://doi.org/10.1016/j.enganabound.2022.10.019>
- Zhiqiang, S., Aiyun, L., Daichang, Z., Shuangjun, L., Habibi, M., Xiaoling, F. and Albaijan, I. (2024), "Application of a folded nanostructure reinforcement for the pole vault curved shell", *Mech. Adv. Mater. Struct.*, 1-15. <https://doi.org/10.1080/15376494.2024.2375368>
- Zhou, C., Zhao, Y., Zhang, J., Fang, Y. and Habibi, M. (2020), "Vibrational characteristics of multi-phase nanocomposite reinforced circular/annular system", *Adv. Nano Res.*, **9**(4), 295-307. <https://doi.org/10.12989/anr.2020.9.4.295>
- Zhu, B., Zhong, Q., Chen, Y., Liao, S., Li, Z., Shi, K. and Sotelo, M.A. (2022a), "A novel reconstruction method for temperature distribution measurement based on ultrasonic tomography", *IEEE T Ultrasonics Ferroelectr. Freq. Control*, 1-1. <https://doi.org/10.1109/TUFFC.2022.3177469>
- Zhu, L., Ren, H., Habibi, M., Mohammed, K.J. and Khadimallah, M.A. (2022b), "Predicting the environmental economic dispatch problem for reducing waste nonrenewable materials via an innovative constraint multi-objective Chimp Optimization Algorithm", *J. Clean. Prod.*, 132697. <https://doi.org/10.1016/j.jclepro.2022.132697>
- Zisong, Z. and Habibi, M. (2024a), "AI-assisted prediction of St14 steel sheets formability: Neural-fuzzy systems and crystal plasticity assessments", *Structures*, **65**, 106633. <https://doi.org/10.1016/j.istruc.2024.106633>
- Zisong, Z. and Habibi, M. (2024b), "AI-assisted prediction of St14 steel sheets formability: Neural-fuzzy systems and crystal plasticity assessments", *Structures*, **65**, 106633. <https://doi.org/10.1016/j.istruc.2024.106633>

AL