

A study on a simulation model of temporary column-to-column joints in steel structural buildings

Koji Moriya*¹, Taiki Hirata^{2a}, Tomoharu Saruwatari^{3b} and Yasuyuki Nagano**⁴

¹Graduate School of Simulation Studies, University of Hyogo, 7-28 Minatojima-minamimachi, Chuo-ku, Kobe City, Hyogo 650-0047, Japan

²Temporary Construction Business Division, Technos Co., Ltd, 2-1Honohara, Toyokawa City, Aichi 442-0061, Japan

³Engineering Technology Division, JSOL Corporation, Tosabori Daibiru Building 2-2-4 Tosabori, Nishi-ku, Osaka City 550-0001, Japan

⁴Graduate School of Disaster Resilience and Governance, University of Hyogo, East Wing, Disaster Reduction and Human Renovation Institution 1-5-2 Wakinohama Kaigan-dori, Chuo-ku, Kobe City, Hyogo 651-0073, Japan

(Received July 10, 2024, Revised November 18, 2024, Accepted November 19, 2024)

Abstract. Currently, in steel erection work in Japan, the wireless steel erection method, which introduced high-strength erection alignment devices to temporary column-to-column joints, is the mainstream method. Due to the tendency for the critical pass to the welding process in order to shorten the construction process, the range of steel frames in a temporary state will expand and its term will be prolonged. Consequently, the importance of seismic safety considerations to temporary column joints grows because of the increased probability of damage and the scale of earthquakes. This study proposes new methodology for evaluation of strength of the temporary column joints with the special alignment devices using finite element (FE) modeling which verifies the seismic safety of steel frames during erection. To this end, it implemented the simulation study of pushover experiments of the temporary column joints (solid models) of square steel tube columns, and the results such as the stress and deformation properties of each component were compared with those calculated by the general conventional stress calculation method, and its validity was confirmed.

Keywords: FEM; seismic; steel structures; temporary column joints; under construction; wireless steel erection method

1. Introduction

Steel frames for construction work must be safely erected to the required accuracy following basic standards (American Institute of steel 2016, Architectural Institute of Japan 2018) and design documents. In the erection of square steel tube columns, temporary column-to-column joints

*Corresponding author, Ph.D. Student, E-mail: moriyapure@outlook.jp

**Corresponding author, Professor, E-mail: nagano@drg.u-hyogo.ac.jp

^a Mr., E-mail: thirata@technos.info

^b Mr., E-mail: saruwatari.tom@jsol.co.jp

(hereinafter referred to as “temporary column joints”) occur, where upper steel columns are temporarily fixed to lower steel columns. Both columns’ erection pieces are basically connected with a splice plate and high-strength bolts. To ensure safety, several anti-tilting wires are stretched between the top of the erected upper-tier steel column and the support point on the lower-tier floor. The erection is aligned by loosening the high-strength bolts on the erection piece, loosening or stretching the anti-tilting wires, and straightening the erection using a hydraulic jack or similar device.

Currently, in Japan, the development of machine-fixed high-strength devices for aligning erected columns (Technos co., Ltd 2024) (hereinafter referred to as “erection alignment devices”) is progressing. This device mechanically and simply fixes the erection pieces of upper and lower steel columns and enables erection alignment with the upper and lower steel columns integrated without tensioning anti-tilting wires (hereinafter referred to as the “wireless steel erection method”). This method has become the mainstream method in steel frame construction in Japan because it greatly improves work efficiency.

The advent of the wireless steel erection method has enhanced steel erection work efficiency. However, welding work on columns is often a critical path in this method because of difficulty of shortening welding process duration due to welder shortage and fluctuations in the amount of welding per erection tier. Consequently, when prioritizing the construction period, the erection work is further advanced before the welding of the lower section steel frame is completed; the area of steel frames placed in a temporary state where welding is not completed becomes increasingly larger and the duration of this temporary state of the erected steel frame also becomes longer. This implies an increase in the seismic load borne by the temporary column joints, as well as an increase in the probability of damage and the size of an earthquake in the steel frame. Therefore, making seismic safety considerations of temporary column joints becomes increasingly very important of steel erection.

Unlike completed buildings, there are no quantitative performance requirements or design procedures specified in legislation or codes for seismic safety evaluation method of supporting structures under construction. Thus, in the case of temporary column joints, as with other temporary components, construction planners compare the short-term allowable stress (yield strength) with the stress calculation results for each component of the temporary column joint (erection alignment devices, erection pieces, and steel columns) as a general seismic safety evaluation. Each of these stresses is calculated at the manual calculation level using a two-dimensional bar model with simplified components and static horizontal loads for seismic forces. This method minimizes the calculation workload, but it does not allow detailed evaluation of the complex local deformations and stresses at the unrestrained ends of square steel tube columns, etc., resulting in an inability to accurately determine “the components that determine the strength of the temporary column joints” and “the seismic forces allowed in the calculation for evaluation”.

The integrated analysis of temporary column joints with the FE model is considered to be an effective mean to solve this issue. The studies that have achieved results in numerical experiments using FE model analysis in buildings include Suna *et al.* (2019) and Mizushima *et al.* (2016), which focused on the structural frame of completed buildings, Cheng-Chih *et al.* (2004) and Ting *et al.* (1993), which focused on column-beam connections. With respect to finishing building components, there are studies on testing and simulation modeling of integral ceilings (Lyu *et al.* 2019). For temporary components, there are modeling studies of tower crane mast joints (Ushio *et al.* 2019a, b).

Various types of temporary column joints applied during steel construction are available and

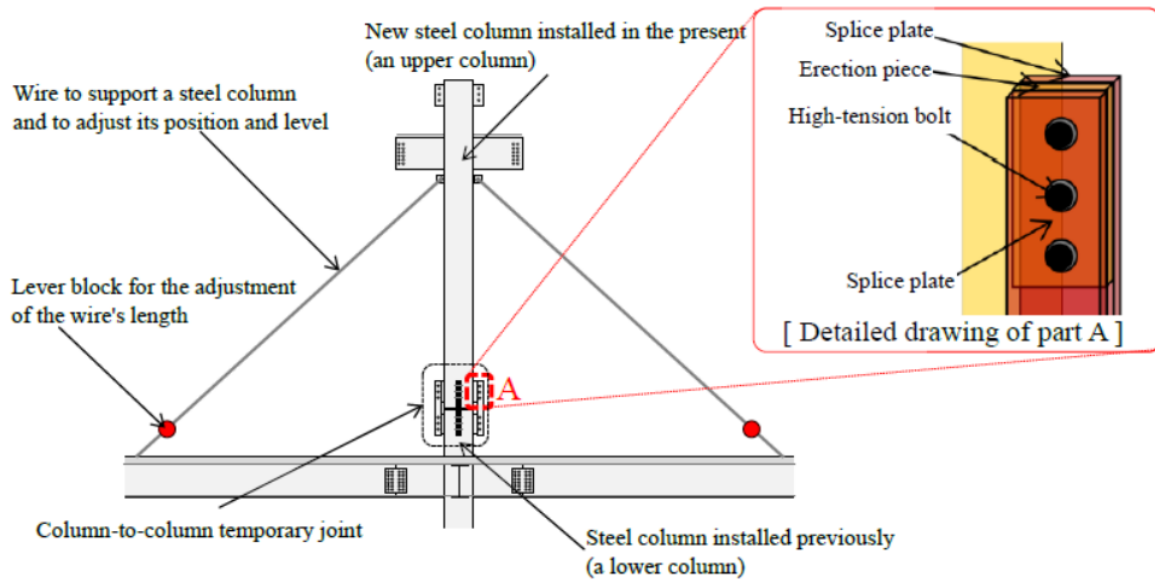

Attention: The position and level of the steel columns are adjusted after the steel beams are installed, but the beams are omitted in this figure.

Fig. 1 A steel frame erection alignment without erection alignment devices

these joints are different from the welding joints and bolting joints applied in permanent connections. Most of the studies have focused on the development of erection alignment devices for adjusting the erection of temporary column joints (Minami *et al.* 2022) or a comprehensive steel erection management system that incorporates temporary column joints (Nishita *et al.* 2004). In a rare study that approached the strength and stiffness of temporary column connections using FEM, Moriya *et al.* (2022) performed flexural shear tests of an erection piece welded to an internally reinforced square steel tube column and compared the strength and stiffness with those from finite element method (FEM) numerical experiments.

This study proposes new methodology for evaluation of strength of the temporary column joints with the special alignment devices using finite element (FE) modeling which verifies the seismic safety of steel frames during erection. To this end, it implemented the simulation study of pushover experiments of the temporary column joints (solid models) of square steel tube columns, and the results such as the stress and deformation properties of each component were compared with those calculated by the general conventional stress calculation method, and its validity was confirmed.

2. Background

2.1 Details of temporary column joints

Fig. 1 shows a steel frame erection alignment without erection alignment devices. Temporary column joints are made by joining upper and lower steel column erection pieces using splice plates and high-strength bolts. In addition, several anti-tilting wires are stretched between the top of the

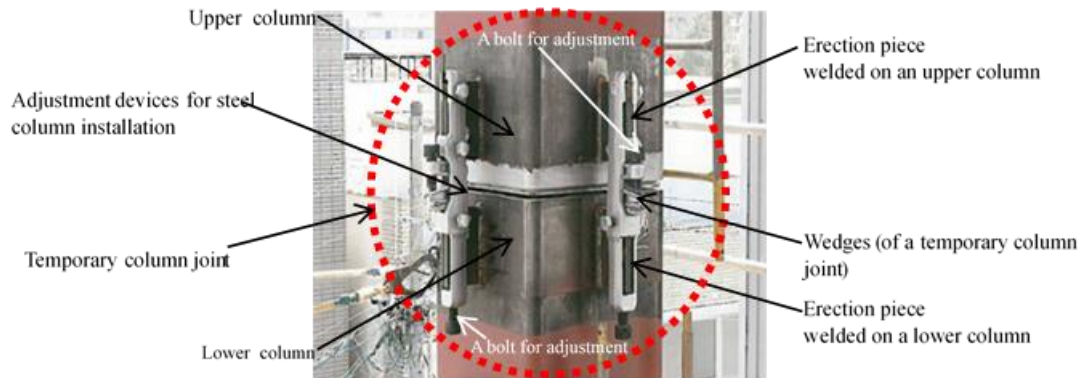

Fig. 2 An example of a temporary column joint using devices for adjusting the insertion

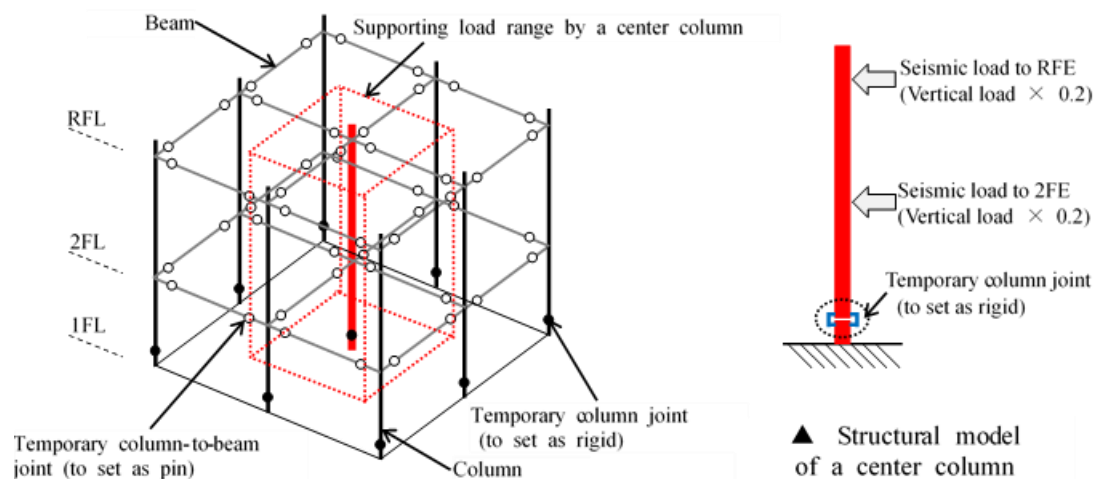

Fig. 3 Simplified structural modeling method of a steel framework in a temporary state for conventional stress calculation methods

erected upper-tier steel column and the support point on the lower-tier floor. The upper steel column is aligned by loosening the high-strength bolts on the erection piece and by loosening or stretching the anti-tilting wires and using a hydraulic jack or similar devices.

Fig. 2 shows an example of a temporary column joint using devices for adjusting the insertion. In the case of these devices, the rectangular ring of high-strength steel is set surrounding the erection pieces of upper and lower columns, and the ring and erection pieces are fixed by frictional and compressive forces by a wedge driven into the gap between the erection pieces and the ring. Then, by tightening or loosening the adjusting bolts of the erection alignment devices, the straightness or position of the upper steel column can be aligned while the upper and lower steel columns and the erection alignment devices are still in one piece. In the case of erection alignment devices developed by other manufacturers, there are some differences in the fixing method and installation, but the configuration of the integration of the erection piece of the steel column with a special device is the same; moreover, if the safety is confirmed by strength calculations, there is no need to erect anti-tilting wires.

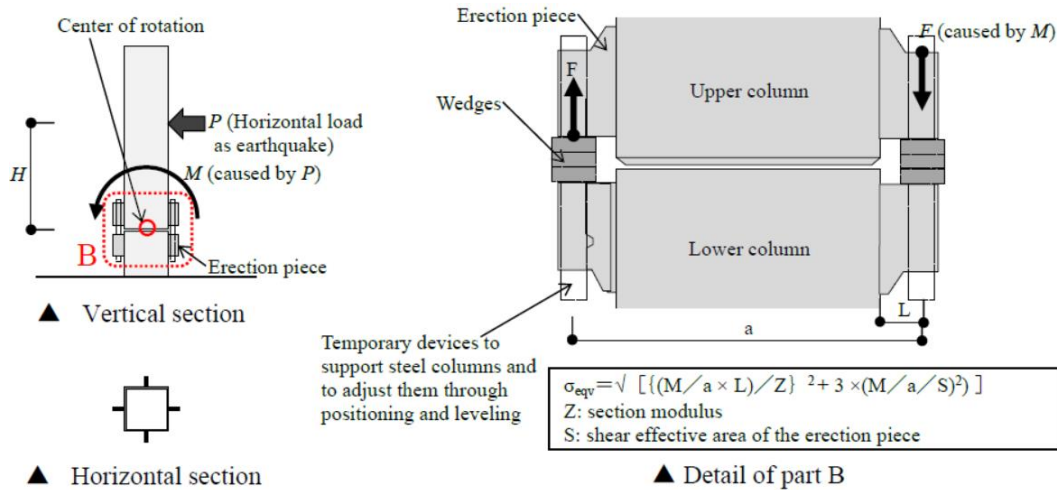

Fig. 4 Simplified structural modeling and stress calculation method for an erection piece

As mentioned earlier, the emergence of wireless steel erection methods has spurred the advancement of the steel erection process. In contrast, welding work has tended to be critical, and the extent of steel frames in a temporary state becomes larger and the duration longer. Then, the safety risks become higher in the wireless steel erection method than in the case without safety devices (e.g., alignment wires) to prevent the collapse of the steel frame in the temporary state. Thus, examining safety during this temporary state is important.

2.2 Conventional stress calculation methods

Conventional stress calculation methods involve replacing the erection alignment devices, the erection pieces, and the steel columns that make up the temporary column joints with a simplified structural model for each of them and calculating the stresses at a manual calculation level.

2.2.1 Structural model of a steel frame structure with temporary column joints

Fig. 3 shows a simplified structural modeling method of a steel frame in a temporary state for conventional stress calculation methods. This is based on the steel erection of a 2-span × 2-span × 2-floor steel frame as a case study. In general, the seismic force used for stress calculations for temporary structures is considered to be a static horizontal load of 20% of the vertical load to be borne by the structure. If all the column temporary joints have the same specifications, the cantilever model can be applied using the loading conditions of the central column temporary joint, which has the greatest seismic load to bear because it bears the largest vertical load.

2.2.2 Calculation methods for each part of a temporary column joint

For conventional stress calculation methods, this section shows how to calculate the stress of each component of temporary column joints.

Fig. 4 shows a simplified structural modeling and stress calculation method for an erection piece. The forces acting on the erection piece (even forces) are calculated from the balancing equation of the rotational moment in the structural model in Fig. 3. Then, the bending shear stress is calculated.

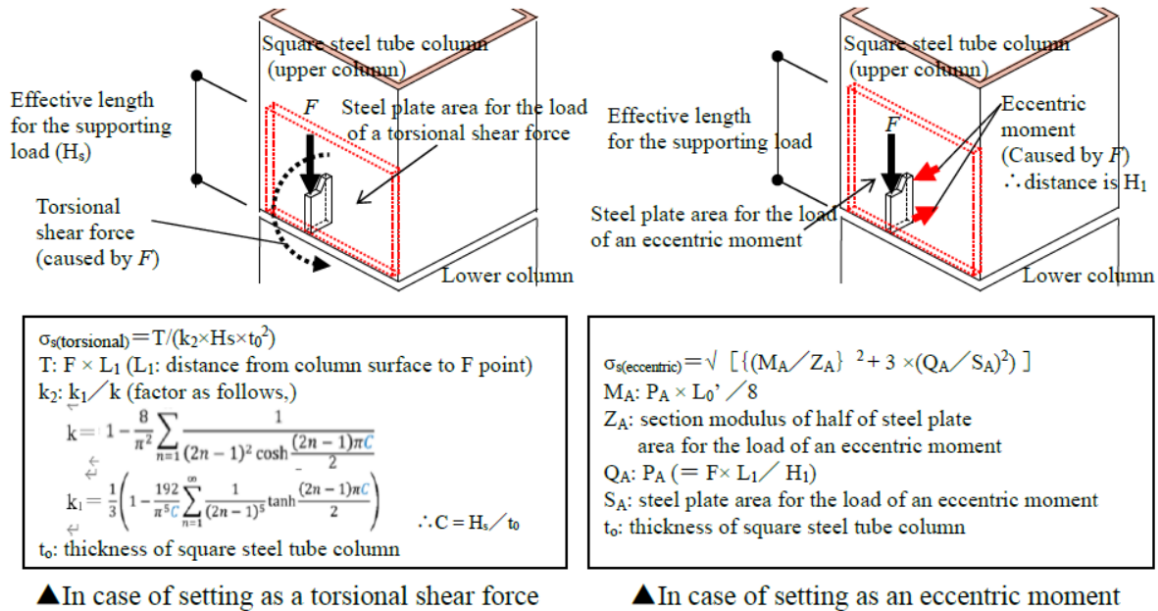

Fig. 5 Main simplified structure modeling for a square steel tube column (made of steel plate) with temporary column joints

The tensile stress of the inserted alignment device can be calculated from the vertical load F on the erection piece. Because such a device is generally made of ultra-high-strength materials, it is rarely a component that determines the bearing capacity of the temporary column joints. However, if it is evaluated, the tensile stress is the target.

Fig. 5 shows the main simplified structure modeling for a square steel tube column (made of steel plate) with temporary column joints. The modeling differs depending on whether the force (F) to the plate from the erection piece is considered to be a torsional shear force or an eccentric moment. In addition, the determination of the stress-bearing width on the steel plate side by the construction planner also greatly affects the calculation results.

3. Outline of numerical experiments

3.1 modeling of numerical experiments on temporary column joints

Fig. 6 shows the details of the steel frame subjected to FEM numerical experiments (seismic force acting at a 90° direction horizontally). Table 1 shows the components and the material properties of the numerical experiments. The purpose of the pushover experiment is to confirm the stress change and deformation behavior of the temporary column joints by applying a rotating moment due to horizontal loads simulating earthquake loads to the temporary column joints of the square steel tube columns and to propose a method for evaluating the bearing capacity of temporary column joints. The details are as follows.

- Numerical experiments assume a model where independent square steel tube columns ($700 \times 700 \times 22$, L8, 800 mm), equivalent to the length of one tier of the column of a steel-

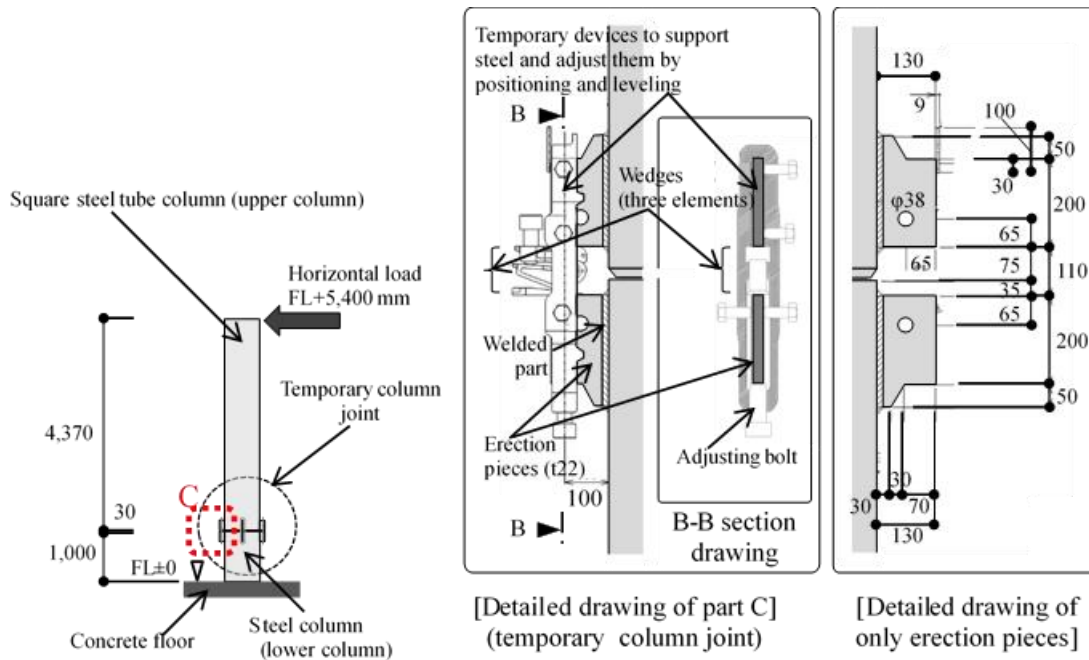

Fig. 6 Details of the steel frame subjected to FEM numerical experiments (seismic force acting at a 90° direction horizontally)

framed office building under construction (Japan Building Disaster Prevention Association 2007), are freestanding via temporary column joints and static horizontal loads simulating seismic forces are applied to the midpoint (FL+5,400 mm) of the upper column length.

- Temporary column joints are placed between the lower and upper columns of the same cross-section, rising 1,000 mm vertically from the concrete floor. Each of the four faces of the columns is simulated as if it were fixed by the upper and lower erection pieces and the erection alignment device.

- The temporary column joints of the columns are shown in Fig. 2.

- The steel tubular columns in the lower tier are fixed to the floor, and the floor is immovable and rigid with sufficient strength.

- Fig. 7 shows the condition of the horizontal loading. The magnitude of the horizontal loading is in the range of 0–250 kN, and the loading is divided into a total of 50 steps. Vertical loads such as the dead weight of the member and working loads are not considered.

- The case of static loads acting at 90° and 45° directions horizontal to the square steel tube column face is the subject of the experiment.

- Ansys LS-DYNA R11 (Rev.134719 [double precision version]) is used for numerical analysis. (Livermore Software Technology Corporation 2015)

- All elements are modeled by Solid.

- In the bending and shear experiment simulation of the erection piece (Moriya *et al.* (2022)), a comparison study between the models with the mesh size of 2 mm and 5 mm was conducted, and the results showed that the model with the 5 mm size elements is enough to calculate the accurate stress and deformation-

Table 1 Components and material properties of the numerical experiments

Name of component	Material	Mass density (ton/mm ³)	Young's modulus (N/mm ²)	Poisson's ratio	Yield stress (N/mm ²)
Steel tube column	SM490	7.89×10^9	2.06×10^5	0.3	350.0
Erection piece	SM490	7.89×10^9	2.06×10^5	0.3	350.0
Temporary devices to support steel and adjust them through positioning and leveling	SCM440-H	7.82×10^9	2.10×10^5	0.3	835.0
Bolt	JIS B1051	7.89×10^9	2.06×10^5	0.3	490
Wedge, other	SM490	7.89×10^9	2.06×10^5	0.3	350.0

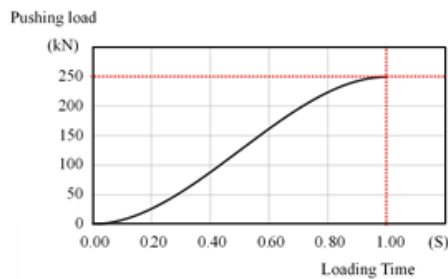

Relational expression between horizontal load and loading ti

- The horizontal load shall be from 0 to 250 kN for 1 s.
- The loading curve approximates the Heaviside function with a cubic polynomial using the following equation:

$$\text{STEP} = \begin{cases} h_0 & (X \leq X_0) \\ h_0 + (h_1 - h_0) \left[\frac{(x - x_0)}{(x_1 - x_0)} \right]^2 \left\{ 3 - 2 \left[\frac{(x - x_0)}{(x_1 - x_0)} \right] \right\} & (X_0 \leq X \leq X_1) \\ h_1 & (X \geq X_1) \end{cases}$$

※ $X_0 = 0.00$ (s), $X_1 = 1.00$ (s), $h_0 = 0$ (kN), $h_1 = 250$ (kN)

Fig. 7 Condition of the horizontal loading

- All materials are defined as bi-linear elastoplastic materials. Material properties are shown in Table 1.

3.2 Devised points of the experimental model

Fig. 8 shows an overview of the modeling of the numerical experiments (pushover experiment). As all the parts of the experiment body in Fig. 6 were reproduced with a solid model consisting of elements of similar sizes, resulting in a huge amount of data and long computation time, the dimensions, specifications, and geometry of the model were devised as follows.

- The model was not considered above FL+5,400 mm, which was the loading point and free edge.

- The area of the square steel tube columns to be modeled with fine solid elements was limited to the region of ± 0 to 2,125-mm FL, and the size of the solid was 5–10 mm per side; the area of $\pm 2,125$ - to 5,400-mm FL was to be modeled as a bar member.

- The model of a complicated temporary device should be made to reproduce the shape as accurately as possible. However, the model of the wedge part should be simplified, and the three parts constituting the wedge part (with Important role in fixing with the erection piece) should be rectangular bodies of the same shape and size with protrusions to prevent dislocation. The coefficient of friction between the steel members was set to 0.1.

- Bevels and backing plates for welds on the upper steel columns were excluded from the

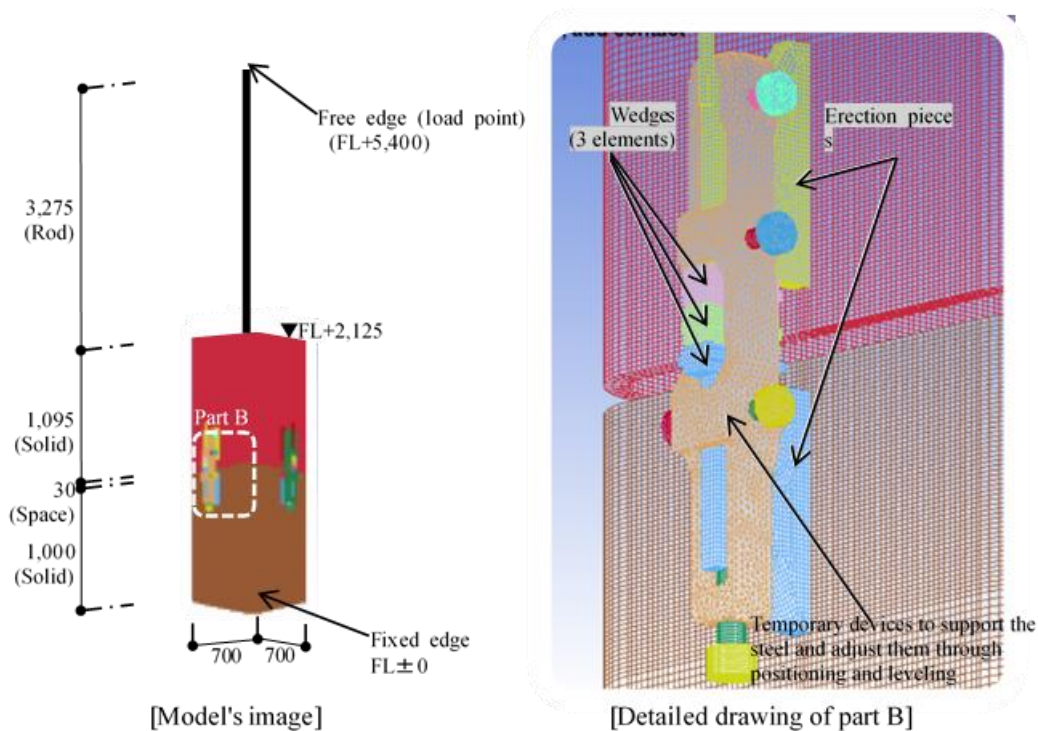

Fig. 8 Overview of the modeling of the numerical experiments (pushover experiment)

modeling, and the gap dimension between the upper and lower square steel tube columns was set to 30 mm.

4. Results of the numerical experiments

4.1 Stress and deformation properties of temporary column joints

Figs. 9-10 show the von Mises stress contour plots (in Step 29 [$P = 147.4$ kN]) at 90° and 45° horizontal pushover. The stresses on the steel plates of the square steel tube columns were highest at the joints between the top and bottom edges of the upper and lower erection pieces at the A-side and C-side, additionally they were highest at the two corners between the A-side and B-side and between the C-side and D-side of the square steel tube columns at a 45° horizontal pushover.

In terms of deformation, at a 90° horizontal pushover, large inward deformation occurred at the joints between the A-side and C-side columns and the erection piece. At a 45° horizontal pushover, large inward deformation occurred at the joints between all columns and erection pieces. The wedge parts of the erection alignment device were maintained without disassembling into pieces.

Fig. 11 shows the stress changes of each part (the erection alignment device, erection pieces, and steel plate of the square steel tube columns) of the A-side constituting the temporary column joints for a 90° horizontal pushover. Each element reached yield stress (the short-term allowable

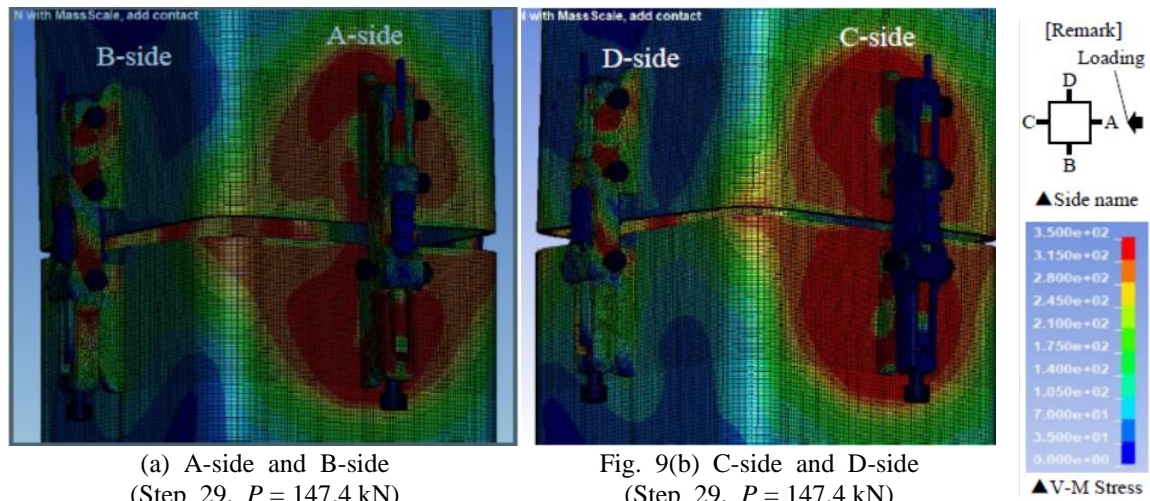

(a) A-side and B-side
(Step 29, $P = 147.4$ kN)

Fig. 9(b) C-side and D-side
(Step 29, $P = 147.4$ kN)

Fig. 9 von Mises stress contour plots (Step 29, $P = 147.4$ kN) at 90°

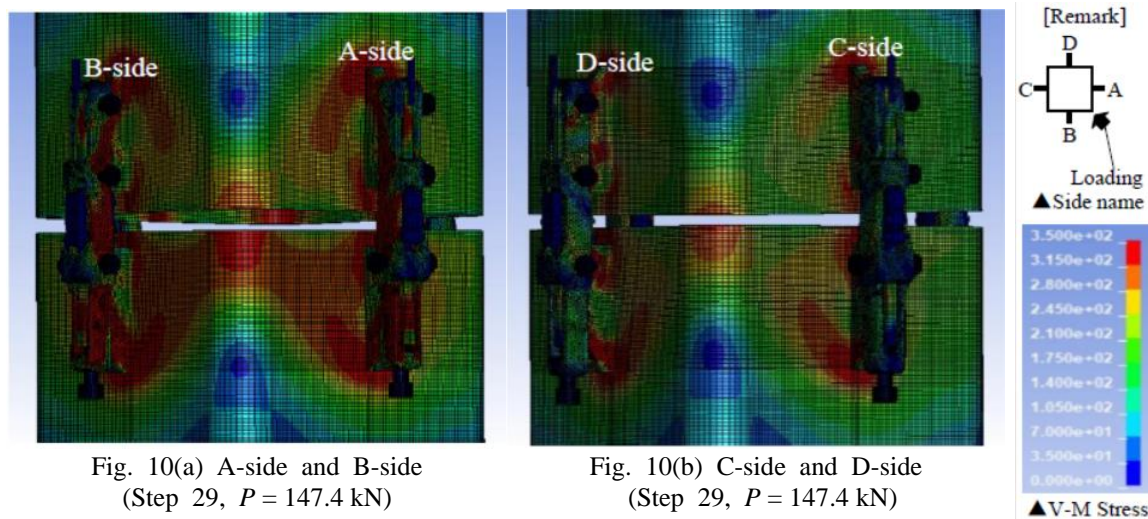

Fig. 10(a) A-side and B-side
(Step 29, $P = 147.4$ kN)

Fig. 10(b) C-side and D-side
(Step 29, $P = 147.4$ kN)

Fig. 10 von Mises stress contour plots (Step 29, $P = 147.4$ kN) at 45°

stress specified in the Japanese standards) at Steps 10–40 for the erection piece, Steps 18–42 for the square steel tube column, and Steps 32–44 for the entry alignment device. The results of this graph and the contour plots (Figs. 9–10) show that the elements of the erection piece and square steel tube columns started to reach yield stress much earlier than the erection alignment fixture. And it is also found that the model of this jig could be simplified (e.g., a bar model) because horizontal slippage did not occur in the wedge section.

4.2 Proposed method for calculating the allowable loading force of temporary column joints

The strength of the temporary column joint means the load step that the temporary column joint can withstand (allowable loading step).

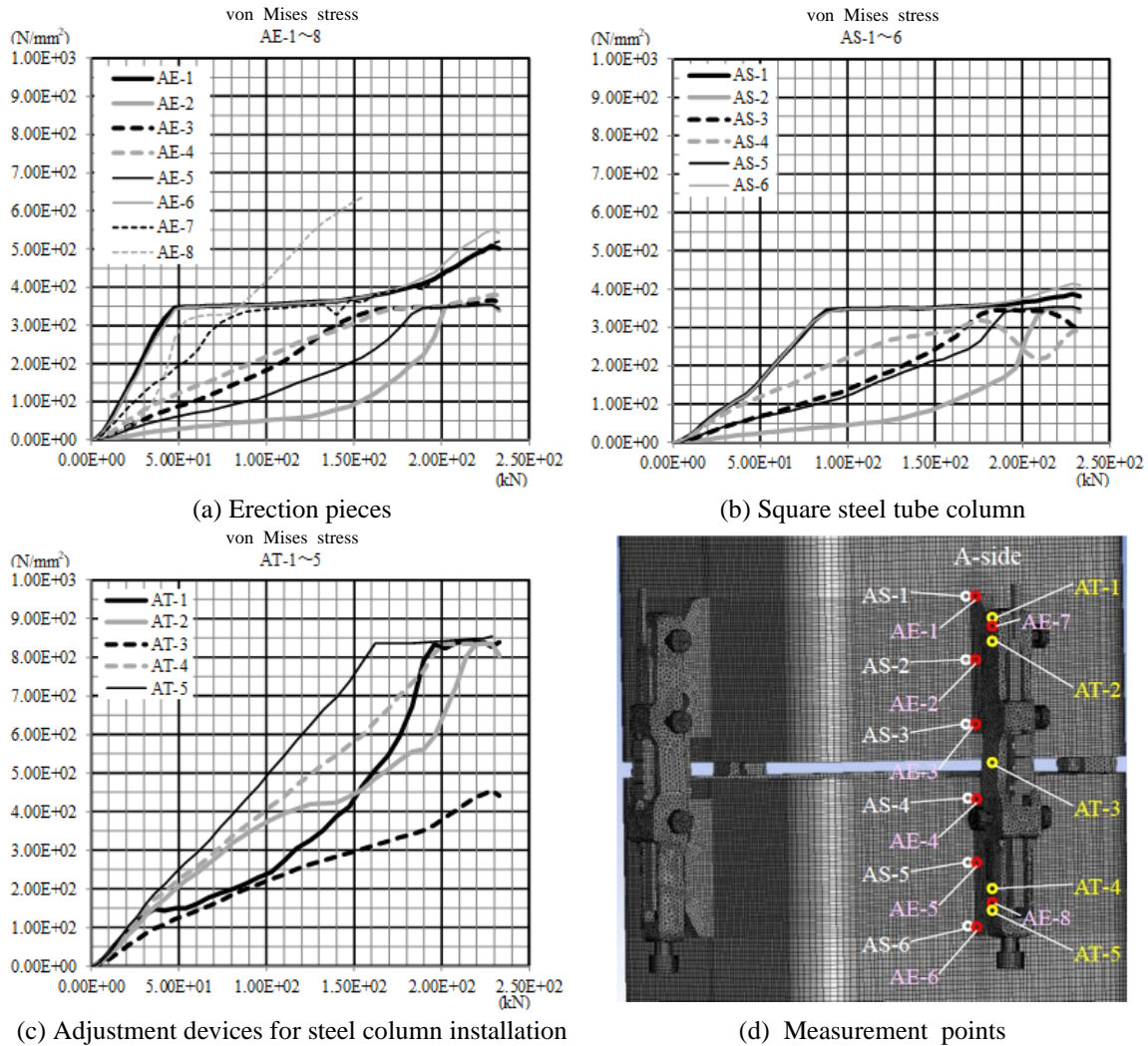

Fig. 11 Stress changes of each part of the A-side constituting the temporary column joint at 90°

A temporary column joint of the square steel tube column consisted of four upper and lower steel skim plates (eight skim plates) of the columns, which were connected by erection pieces (eight pieces) and a built-in alignment device (four devices) to bear the vertical and horizontal loads. Therefore, if any one load capacity of these 20 parts (eight plates + eight pieces + four devices) was lost, the original structural safety function of the temporary column joint could not be maintained. In other words, the allowable load step of the temporary column joint is the load step at which the weakest component reaches the short-term allowable stress (yield strength).

(1) Method for determining the allowable loading step at the yielding of an erection piece (Fig. 12)

The FEM contour stress diagram for the step where the first FEM element of the subjected erection piece reaches yield strength (Step E₁) is shown in Fig. 12(a), and the FEM contour stress diagram at the step where the erection piece is in a full plastic state (Step E₂) is shown in Fig.

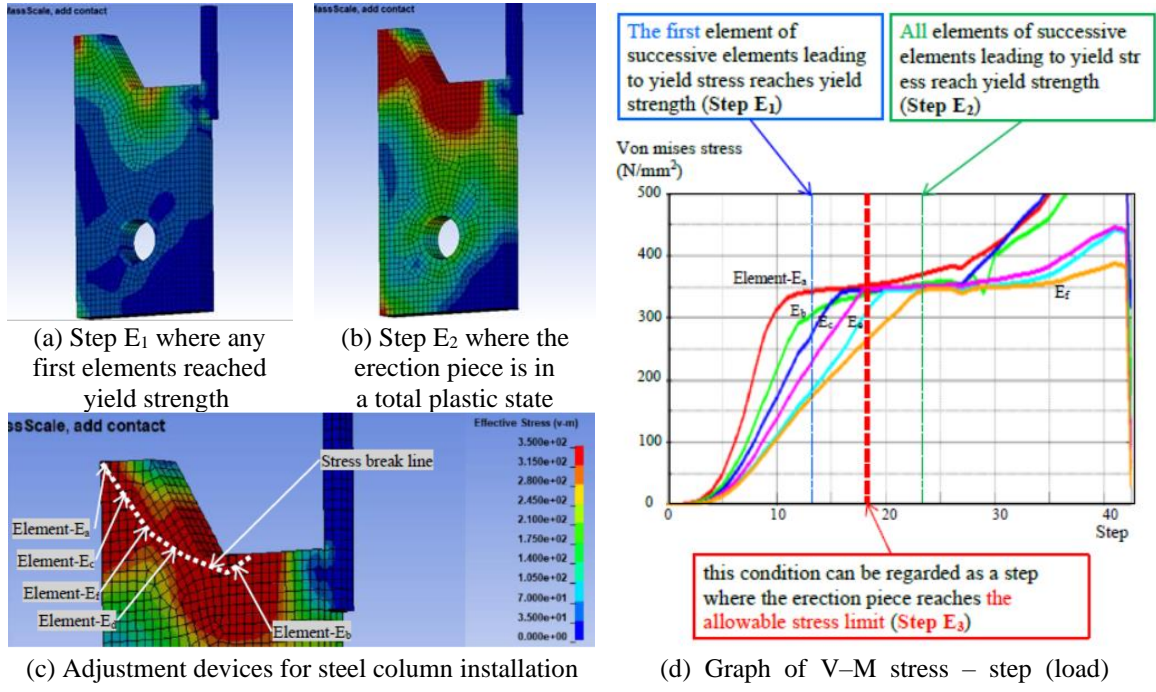

Fig. 12 Method for determining the allowable loading step at the yielding of an erection piece

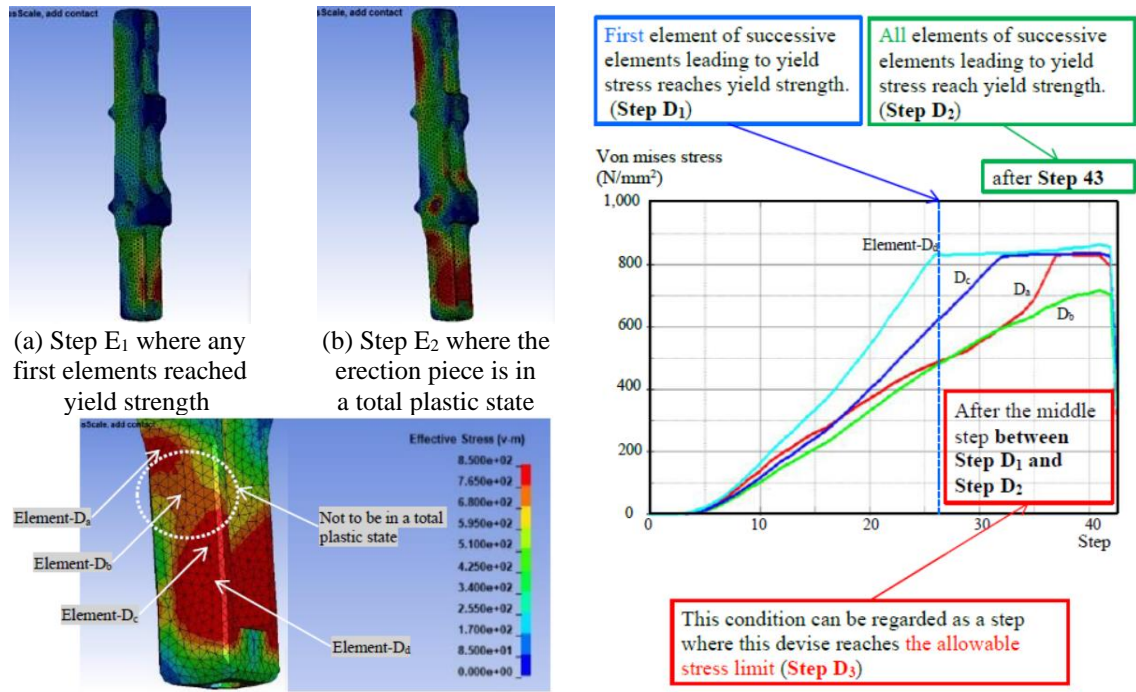

Fig. 13 Method for determining the allowable loading step at the yielding of a device for erection alignment

12(b). According to these diagrams, the stress fracture line of the erection piece is considered as shown in Fig. 12(c). The graph of the V–M stress–loading step of representative elements (E_a to E_c) on the stress fracture line is shown in Fig. 12(d).

The step where the erection piece reached its yield strength was considered to exist between Step E_1 and Step E_2 . This midpoint step (Step E_3) was evaluated as the step of “the allowable loading force at the erection piece yielding.” The allowable loading step of the other seven pieces’ yielding can be determined in the same way.

(2) Method for determining the allowable loading step at the yielding of a device for erection alignment (Fig. 13)

Fig. 13(a) shows the FEM contour stress diagram for the step where the first FEM element of the target device reaches yield strength (Step D_1), and Fig. 13(b) shows the FEM contour stress diagram for the final loading step of the device (Step 43). The stress fracture line of the device, which was important for the support relationship with the erection piece, was unknown because the device had high yield strength and did not enter a plastic state under the experimental loading conditions. Representative elements (Fig. 13(c), D_a – D_d) with fast stress increase against load were selected, and the stress–loading step graph is shown in Fig. 13(d).

Essentially, in the same way as in the previous step (1), the “allowable loading step at the erection alignment device yielding” was evaluated at the midpoint step (Step D_3) between Step D_1 and Step D_2 , where the erection adjustment device was in a total plastic state. In the case of this fixture, Step D_2 was unknown, but it was considered to be larger than the midpoint step of Step D_1 and Step 43. The allowable loading step of the other three devices could be determined in the same way.

(3) Method for determining the allowable loading step at steel skin plate yielding in square steel tube columns (Fig. 14)

The FEM contour stress diagram at the step where the first element of the steel plate of the subjected square steel tube column reaches yield strength (Step S_1) is shown in Fig. 14(a), and the FEM contour stress diagram at the step where the subjected steel plate is in a full plastic state with respect to the support performance of the element piece (Step S_2) is shown in Fig. 14(b). The stress fracture line is considered to be as shown in Fig. 14(c). The V–M stress–loading step graph of the typical elements on the stress fracture line (S_a to S_c) is shown in Fig. 14(d).

The step where the subjected steel plate reached yield strength was between Step S_1 and Step S_2 . This midpoint step (Step S_3) was evaluated as the step of “the allowable loading force at the subjected steel plate yielding.” The same method could be used to determine the allowable loading step at the steel plate yielding of the other seven plates.

(4) Method for determining the allowable loading step of a temporary column joint

Based on the methods described in (1) to (3) above, the loading step of a temporary column joint when the 20 parts (eight surfaces + eight pieces + four devices) reach yield strength were calculated, and the lowest value was the allowable loading force of a temporary column joint. It was not necessary to calculate the allowable loading step of the temporary column joint when its parts were known to be sufficiently high in advance from stress contour drawings, among others (e.g., devices for adjusting installation).

4.3 Examples of the allowable loading step Calculations for Temporary Column Joints

For a case study, the allowable loading step of temporary column joints were determined following the methods described in Section 4.3.

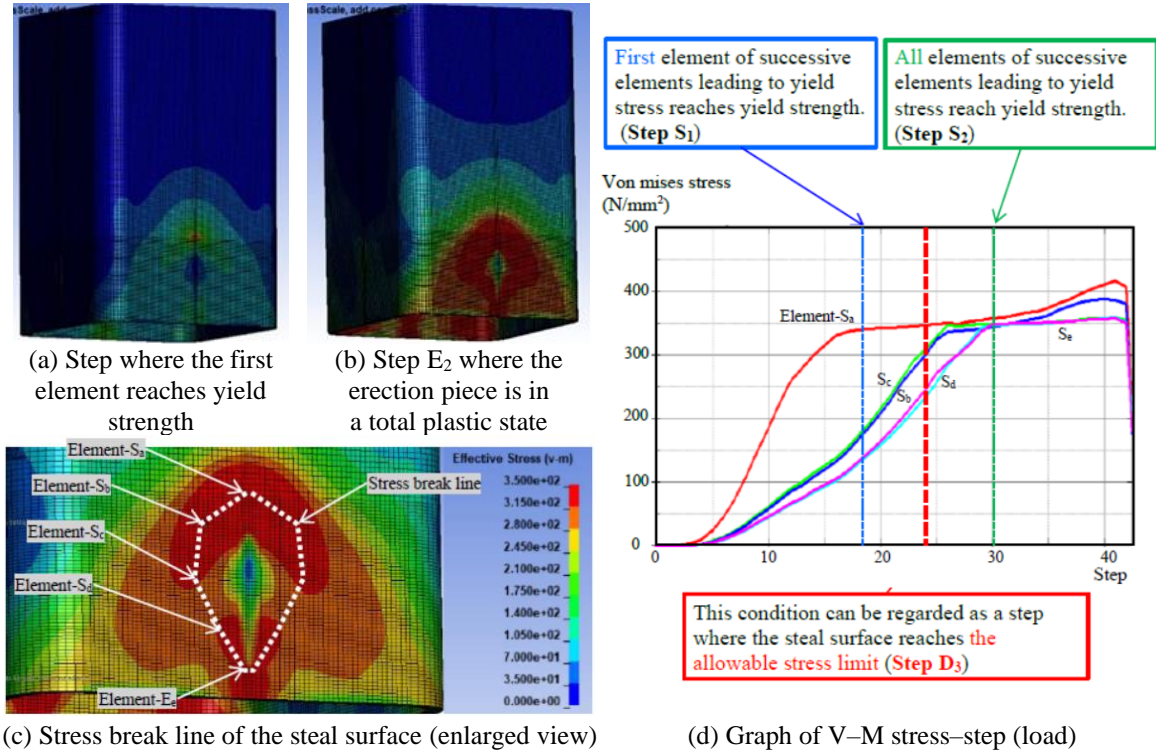

Fig. 14 Method for determining the allowable loading step at steel skin plate yielding in the square steel tube columns

Table 2 Parts subjected to the allowable loading step determination of the temporary column joint

Parts	Horizontal 90° pushover								45°
	A-Side		B-Side		C-Side		D-Side		A-Side
	Upper	Lower	Upper	Lower	Upper	Lower	Upper	Lower	Lower
Erection piece	●	●	—	—	●	●	—	—	●
Surface of the steel tube column	●	●	—	—	●	●	—	—	●
Device	—	—	—	—	—	—	—	—	—

Note: ●···Target of analysis; —···not subject to calculation

Table 2 shows the parts subjected to the allowable loading force calculations of the temporary column joints. The B-side and D-side parts of these square tube column faces that were not on the compression or tension side, as well as the alignment device, were excluded from the calculation, considering the loading direction and yield strength of the parts. In addition, the bearing capacity of temporary column joints under 45° horizontal loading was higher than that under 90° horizontal loading, so this was not a critical case. Therefore, two parts were included in the calculation for reference.

Fig. 15 shows the stress variation by loading steps of the subjected parts.

Table 3 shows the loading step when each part reaches yield strength.

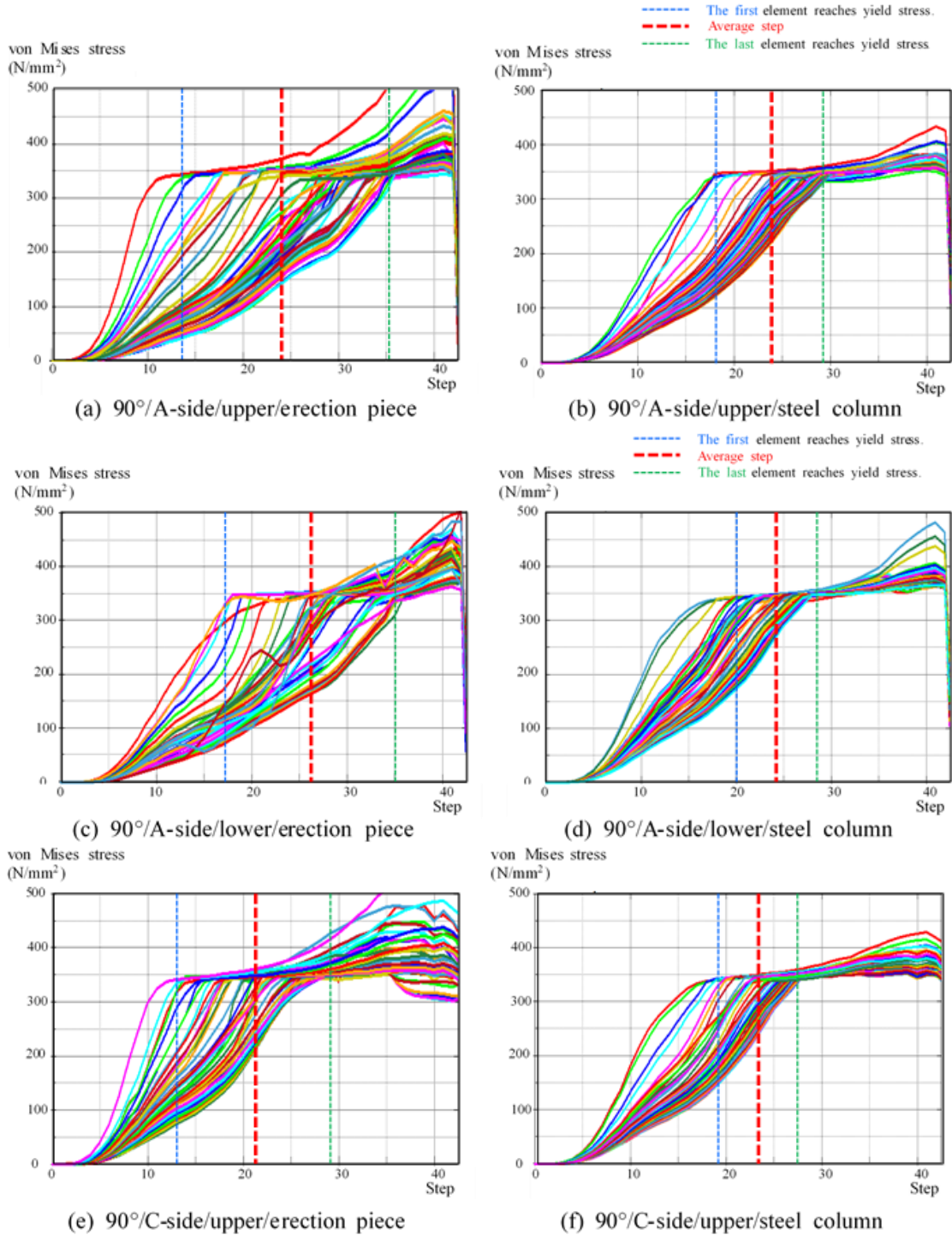
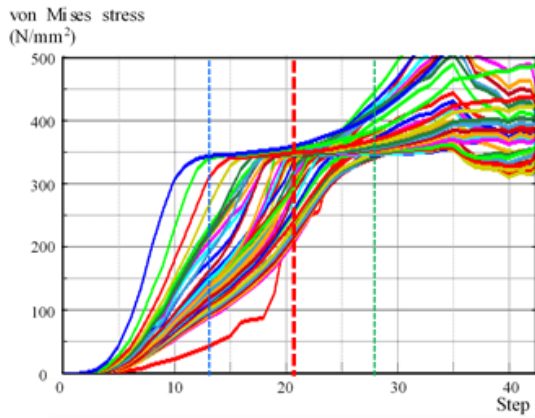
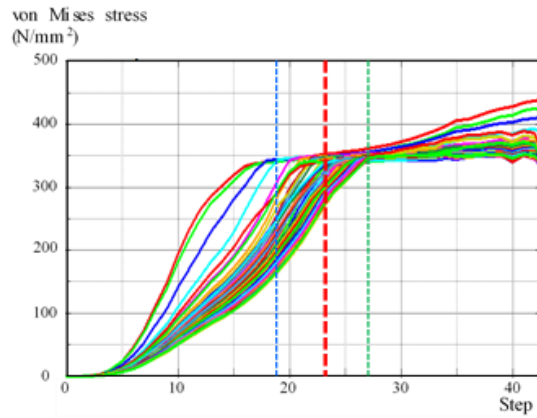

Fig. 15 Stress variation by loading steps of the subjected part 2



(g) 90°/C-side/lower/erection piece



(h) 90°/C-side/lower/steel column

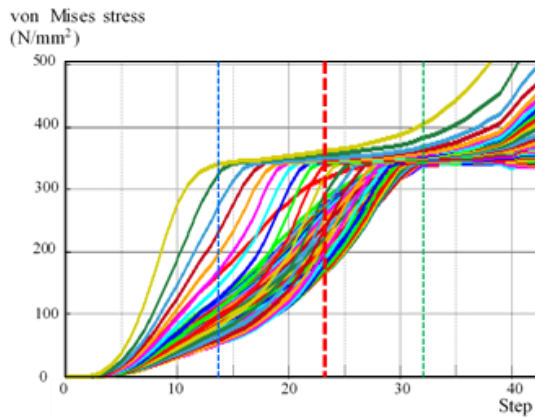

Fig. 15(i) 45°/A-side/lower/erection piece

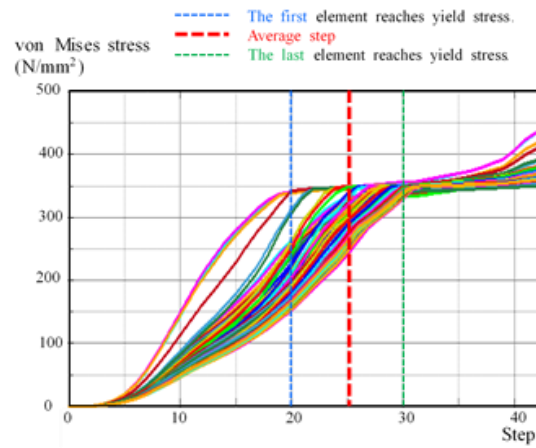

Fig. 15(j) 45°/A-side/lower/steel column

Fig. 15 Continued

Table 3 Loading step when each part reaches yield strength

Parts	Horizontal 90° pushover								45°
	A-Side		B-Side		C-Side		D-Side		A-Side
	Upper	Lower	Upper	Lower	Upper	Lower	Upper	Lower	Lower
Erection piece	Step 24	Step 26	—	—	Step 21	Step 20.5*	—	—	Step 23
Surface of the steel tube column	Step 23.5*	Step 24	—	—	Step 23	Step 23	—	—	Step 25
Device	—	—	—	—	—	—	—	—	—

Note: ●●●Target of analysis; —●●●not subject to calculation

Table 3 shows that the first part to reach yield strength is the lower column erection piece at the C-Side (Step 20.5: $T = 4.1$ (s), $P = 91.7$ (kN)), and 91.7 kN is the allowable loading force of the temporary column joint.

Table 4 Comparison of the results of the conventional stress calculation method (see Figs. 3–5) and the FEM method

Parts	Erection piece		Square steel column		
	Convenience method	This method	Convenience method		This method
			Set as torsional shear force	Set as an eccentric moment	
A yield step	Step 22	Step 20.5	Step 12	Step 23	Step 23
Time (s)	0.44	0.41	0.24	0.46	0.46
Load (kN)	103	91.7	36.3	110	110

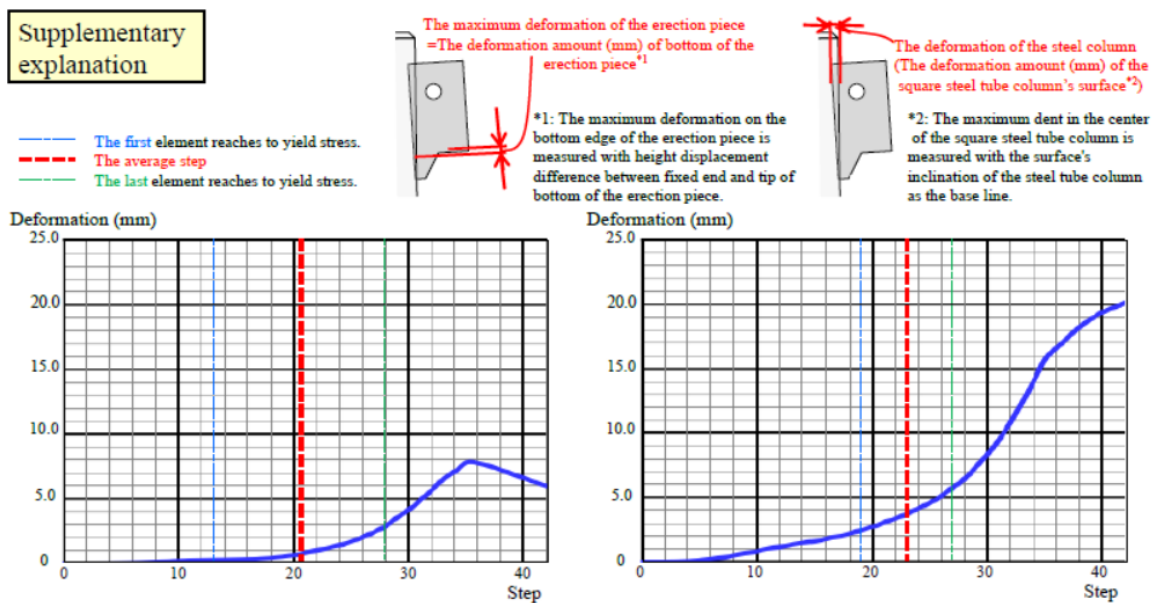

Fig. 16 graph of the load-deformation (relative displacement) at the representative points

Table 4 compares the results of the conventional stress calculation method (see Figs. 3-5) and the FEM method. There is no significant difference between the results of the conventional calculation method and this method for the loading step where the erection piece reaches yield strength. The conventional calculation of the erection piece is a theoretical solution by a simple cantilever beam (Fig. 4), which supports the validity of the present method. For the loading step where the steel plates of steel tube columns reach yield strength, among the conventional stress calculation methods, the eccentric moment method does not differ significantly from the present FEM method, but the torsional shear method does not make much difference. The torsional shear method is considered excessively safe.

4.4 Evaluation of deformation

Fig. 16 superposes the graph showing the loading steps-deformation (relative displacement) at the representative points (maximum deformation) of the erection piece (90°, C-side and upper) and

the steel plate (90°, C-side and upper) , on the graph showing the loading steps and the stresses of the main elements which also identifies the steps of the first element reaching to yield stress, the last element reaching yield stress and the average. Since the deformation amount at the allowable loading step is small and no significant deformation is observed, it can be concluded that the strength of the temporary column joint is determined by the stress conditions.

5. Conclusions

This study proposed new methodology for evaluating the strength of temporary column joints using finite element (FE) modeling to evaluate the seismic safety. The modeling was conducted as follows,

- The FEM model consisted of a solid element portion, which was 1 m above and below the column splice, and a beam element (one-dimensional) portion.
- The complex devices for aligning the erected columns should be modeled by reproducing their shape in as much detail as possible, but the wedge part should be a simplified model where each contact surface transmits only compressive force.

Pushover experiments were conducted on temporary column joints (solid model) of 700 x 700 x 22 square steel tube columns to confirm the stress and deformation of each component, and to compare the results with those of general conventional stress calculation methods.

- The stresses on the steel plate face of the square steel tube column were the greatest at the upper and lower ends of the joint between the upper and lower erection pieces and the column plates in the case of the 90° horizontal pushover and at the compressive and tensile corners of the steel tube column (two corners) in addition in the case of the 45° horizontal pushover.

- In the 90° horizontal pushover, large inward deformation occurred at the joints between the column plate and the erection piece on the compression side and the tension side of the column. In the 45° direction pushover, large inward deformation occurred at all joints between the column plate and the erection piece.

- The elements of the erection piece and the square tube columns began to reach yield stress considerably earlier than erection alignment devices. The fact that no horizontal slip occurred at the wedge that secures the element piece in the jig indicates that a simplified model (e.g., a bar model) can be used for this erection alignment devices.

- A method was proposed to determine the allowable loading step of the temporary column joints (the load applied to the point where the joint components reached the short-term allowable stress [yield strength]) using the stress fracture lines and stress-load step curves of the contour diagram of each part of the temporary column joints of square steel tube columns. The lowest of these values was the allowable loading step of the temporary column joints.

- The results of the calculation of the allowable loading force of the joint when the erection piece yielded using the proposed method were not significantly different from the results obtained using the conventional calculation method. The conventional calculation of the erection piece is a theoretical solution by a simple cantilever beam (Fig. 4), which supports the validity of the present method.

- There was little difference in the results between the proposed method and the conventional eccentric moment method, but the difference was very large when comparing the results of the proposed method with those of the torsional shear method. The torsional shear method is considered excessively safe.

It is expected and confirmed that this study will contribute to more accurate and efficient seismic safety assessment for the steel erection, which trends to expand area and period of the steel frames under temporary state by using the special temporary column joints with alignment devices.

Acknowledgments

In this study, Dr. Ushio (Visiting Researcher Graduate School of Simulation Studies University of Hyogo) assisted with the review of the experiments and the numerical analysis. The authors express special thanks to him.

And the authors would like to thank Enago (www.enago.jp) for the English language review.

References

- American Institute of Steel (2016), *Construction Code of Standard Practice for Steel Buildings and Bridges*, American Institute of Steel erect, Chicago, **16**(3), 40-49.
- Architectural Institute of Japan (2018), *Technical Recommendations for Steel Construction for Buildings Part2 Guide to Erection and Construction in Site (in Japanese)*, Architectural Institute of Japan, Japan, 190-220.
- Cheng-Chih, C., Chun-Chou, L. and Chia-Liang, T. (2004), "Evaluation of reinforced connections between steel beams and box columns", *Eng. Struct.*, **26**(13), 1889-1904.
<https://doi.org/10.1016/j.engstruct.2004.06.017>
- Japan Building Disaster Prevention Association (2007), Structural design and component cross-section examples, 554-559, Japan Building Disaster Prevention Association, Toranomom, Minato-ku, Tokyo, Japan.
- Livermore Software Technology Corporation (2015), LS-DYNA Keyword User's Manual Volume II Material Models LS-DYNA R8.0 03/18/15 (r:6307), 2015, ANSYS, Pittsburgh, Pennsylvania, U.S.A.
- Lyu, Z., Sakaguchi, M., Saruwatari, T. and Nagano, Y. (2019), "Tests of integrated ceilings and the construction of simulation models", *Adv. Comput. Des.*, **4**(4), 381-395.
<https://doi.org/10.12989/acd.2019.4.4.381>
- Minami, T., Izawa, K., Nishino, K. and Sato, T. (2000), "Development of plumbing device for structural steel column (in Japanese)", *AIJ J. Technol. Des.*, **11**, 21-26, https://doi.org/10.3130/aijt.6.21_2
- Mizushima, Y., Mukai, Y., Namba, H., Taga, K. and Saruwatari, T. (2018), "Super-detailed FEM simulations for full-scale steel structure with fatal rupture at joints between members—Shaking-table test of full-scale steel frame structure to estimate influence of cumulative damage by multiple strong motion: Part 1", *Japan Arch. Rev.*, **1**(1), 96-108, <https://doi.org/10.1002/2475-8876.10016>
- Moghaddam, S.H. and Masoodi, A.R. (2019), "Elastoplastic nonlinear behavior of planar steel gabled frame", *Adv. Comput. Des.*, **4**(4), 397-413. <https://doi.org/10.12989/acd.2019.4.4.397>
- Moriya K., Saruwatari, T., Hirata, T. and Nagano, Y. (2022), "A study on the seismic disaster risk assessment for buildings under construction in urban areas -safety study method on column-to-column temporary joints of steel structure", *Annual J. Urban Disaster Reduct. Res.*, **9**.
https://dlisv03.media.osaka-cu.ac.jp/il/meta_pub/G0000438repository_24354910-9-42
- Nishita, K., Suzuki, K. and Ishikawa, K., (2004), "Development of New control system of plumbing accuracy in steel work applying column-field-welding robot (in Japanese)", *AIJ J. Technol. Des.*, **19**, 25-28, <https://doi.org/10.3130/aijt.10.25>
- Technos co., Ltd (2014), Temporary Construction Business, Toyokawa-city Aichi-Pref, Japan.
<https://www.technos.info/eng/business/index.html>
- Ting, L.C., Shanmugam, E.N. and Lee, S. (1993), "Design of I-beam to box-column connections stiffened

externally”, *Eng. J AISC*, **30**(4), 141-149, <https://doi.org/10.62913/engj.v30i4.1279>

Ushio, Y., Saruwatari, T. and Nagano, Y. (2019a), “Elastoplastic FEM analysis of earthquake response for the field-bolt joints of a tower-crane mast”, *Adv. Comput. Des.*, **4**(1), 53-72. <https://doi.org/10.12989/acd.2019.4.1.053>

Ushio, Y., Saruwatari, T. and Nagano, Y. (2019b), “A new design method for site-joints of the tower crane mast by non-linear FEM analysis”, *Adv. Comput. Des.*, **4**(4), 343-365. <https://doi.org/10.12989/acd.2019.4.4.343>

TK